



Data Sheet

MM32F0140

Arm® Cortex®-M0 based 32-bit Microcontrollers

Revision: 1.07

MindMotion has the right to make any changes and releases to the information contained in this document (including but not limited to specifications and product descriptions) at any time. This document will replace all previously published information.

Contents

1	Introduction	1
1.1	Overview	1
1.2	Key features	1
2	Ordering information	4
2.1	Ordering table	4
2.2	Marking information	6
2.3	Part identification	9
3	Functional description	10
3.1	Block diagram	10
3.2	Core introduction.....	11
3.3	Bus introduction	11
3.4	Memory map	11
3.5	Flash	13
3.6	SRAM.....	13
3.7	NVIC.....	13
3.8	EXTI	13
3.9	Clock and boot	13
3.10	Boot modes	14
3.11	Power supply schemes	14
3.12	Power supply supervisors	14
3.13	Voltage regulator.....	15
3.14	Low power mode.....	15
3.15	Hardware divider.....	16
3.16	DMA	16
3.17	Timers and watchdogs	16
3.18	GPIO	19
3.19	UART	19
3.20	I2C.....	19
3.21	SPI	19
3.22	I2S.....	19
3.23	FlexCAN.....	19
3.24	ADC.....	20
3.25	COMP	20
3.26	CRC	20
3.27	SWD.....	20
4	Pinout and assignment	21
4.1	Pinout diagram	21
4.2	Pin assignment	26
4.3	Pin multiplexing.....	29
5	Electrical characteristics	33
5.1	Test condition.....	33
5.1.1	Load capacitor.....	33
5.1.2	Pin input voltage.....	33
5.1.3	Power scheme	33
5.1.4	Current consumption measurement	34
5.2	Absolute maximum rating	34
5.3	Operating conditions	35

5.3.1	General operating conditions	35
5.3.2	Operating conditions at power-up/power-down	36
5.3.3	Embedded reset and power control block characteristics	37
5.3.4	Built-in voltage reference	38
5.3.5	Supply current characteristics	38
5.3.6	External clock source characteristics	41
5.3.7	Internal clock source characteristics	44
5.3.8	PLL characteristics	45
5.3.9	Memory characteristics	45
5.3.10	EMC characteristics	46
5.3.11	Functional EMS (Electrical Sensitivity)	47
5.3.12	I/O port characteristics	48
5.3.13	NRST pin characteristics	50
5.3.14	Timer characteristics	51
5.3.15	Communication interfaces	52
5.3.16	FlexCAN interface	57
5.3.17	ADC characteristics	57
5.3.18	Temperature sensor characteristics	61
5.3.19	Comparator characteristics	62
6	Package dimensions	63
6.1	LQFP48	63
6.2	LQFP32	65
6.3	QFN32	67
6.4	QFN28	69
6.5	TSSOP20	71
7	Revision history	73

Tables

Table 2-1 MM32F0140 ordering table 1	4
Table 2-2 MM32F0140 ordering table 2	5
Table 3-1 Memory map.....	11
Table 3-2 Peripheral status in different power modes	16
Table 3-2 Feature summary of advanced, general purpose and basic timers	17
Table 4-1 Pin assignment table	26
Table 4-2 PA port multiplexing AF0-AF8	29
Table 4-3 PB port multiplexing AF0-AF8	30
Table 4-4 PC port multiplexing AF0-AF8	31
Table 4-5 PD port multiplexing AF0-AF8	32
Table 5-1 Voltage characteristics	35
Table 5-2 Current characteristics.....	35
Table 5-3 General operating conditions.....	36
Table 5-4 Operating conditions at power-up/power-down.....	36
Table 5-5 Embedded reset and power control block characteristics	37
Table 5-6 Build-in voltage reference	38
Table 5-7 Typical current consumption in Run mode	39
Table 5-8 Typical current consumption in Sleep mode	39
Table 5-9 Typical and maximum current consumption in stop and Standby modes ⁽¹⁾	39
Table 5-10 On-chip peripheral current consumption ⁽¹⁾	40
Table 5-11 Wake up time from low power mode	41
Table 5-12 High-speed external user clock characteristics	42
Table 5-13 HSE oscillator characteristics ⁽¹⁾⁽²⁾	43
Table 5-14 HSI oscillator characteristics ⁽¹⁾⁽²⁾	44
Table 5-15 LSI oscillator characteristics ⁽¹⁾	44
Table 5-16 PLL characteristics ⁽¹⁾	45
Table 5-17 Flash memory characteristics.....	45
Table 5-18 Flash memory endurance and data retention ⁽¹⁾⁽²⁾	45
Table 5-19 EMS characteristics.....	46
Table 5-20 ESD & LU characteristics	47
Table 5-21 I/O static characteristics	48
Table 5-22 Output voltage static characteristics.....	49
Table 5-23 I/O AC characteristics ⁽¹⁾⁽²⁾⁽³⁾	49
Table 5-24 NRST pin characteristics	50
Table 5-25 TIMx ⁽¹⁾ characteristics.....	51
Table 5-26 I2C characteristics	52
Table 5-27 SPI characteristics ⁽¹⁾	54
Table 5-28 ADC characteristics	58
Table 5-29 Maximum R _{AIN} at f _{ADC} = 15MHz ⁽¹⁾	59
Table 5-30 ADC static parameters ⁽¹⁾⁽²⁾	59
Table 5-31 Temperature sensor characteristics ⁽³⁾⁽⁴⁾	61
Table 5-32 Comparator characteristics ⁽¹⁾	62
Table 6-1 LQFP48 package dimension details.....	64
Table 6-2 LQFP32 package dimension details.....	66
Table 6-3 QFN32 package dimension details	68
Table 6-4 QFN28 package dimension details	70
Table 6-5 TSSOP20 package dimension details	72
Table 8-1 Revision history	73

Figures

Figure 2-1 LQFP or QFN32 package marking.....	6
Figure 2-2 QFN28 package marking	7
Figure 2-3 TSSOP20 package marking.....	8
Figure 7-1 Part number naming rule.....	9
Figure 3-1 System block diagram	10
Figure 4-1 LQFP48 pinout diagram	21
Figure 4-2 LQFP32 pinout diagram	22
Figure 4-3 QFN32 pinout diagram	23
Figure 4-4 QFN28 pinout diagram	24
Figure 4-5 TSSOP20 pinout diagram	25
Figure 5-1 Load condition of the pin	33
Figure 5-2 Pin input voltage.....	33
Figure 5-3 Power scheme.....	34
Figure 5-4 Current consumption measurement scheme	34
Figure 5-5 Power-on and power-down waveforms.....	37
Figure 5-6 High-speed external clock source AC timing diagram	42
Figure 5-7 Typical application with an 8 MHz crystal	44
Figure 5-8 I/O AC characteristics.....	50
Figure 5-9 Recommended NRST pin protection	51
Figure 5-10 I2C bus AC waveform and measurement circuit ⁽¹⁾	53
Figure 5-11 SPI timing diagram-slave mode and CPHA = 0, CPHASEL = 1	55
Figure 5-12 SPI timing diagram-slave mode and CPHA = 1, CPHASEL = 1 ⁽¹⁾	56
Figure 5-13 SPI timing diagram-master mode, CPHASEL = 1 ⁽¹⁾	57
Figure 5-14 Schematic diagram of ADC static parameters	60
Figure 5-15 Typical connection diagram using the ADC	60
Figure 5-16 Power supply and reference power supply decoupling circuit	61
Figure 6-1 LQFP48 package dimension	63
Figure 6-2 LQFP32 package dimension	65
Figure 6-3 QFN32 package dimension.....	67
Figure 6-4 QFN28 package dimension.....	69
Figure 6-5 TSSOP20 package dimension	71

1 Introduction

1.1 Overview

The MM32F0140 microcontrollers are based on Arm® Cortex®-M0 core. These devices have a maximum clocked frequency of 72MHz, built-in 64KB Flash storage, and contain an extensive range of peripherals and I/O ports. These devices contain one 12-bit ADC, one analog comparator, one 16-bit advanced timer, one 16-bit and one 32-bit general purpose timers and three 16-bit basic timers, as well as communication interfaces including one I2C, two SPI or I2S, three UART and one FlexCAN interface.

The operating voltage of this product series is 2.0V to 5.5V, and the operating temperature range (ambient temperature) includes the industrial tier -40°C to 85°C and the extended industrial tier -40°C to 105°C. Multiple sets of power-saving modes make the design of low-power applications possible.

The target applications of this product series include:

- Industrial IoT devices
- PC accessories
- Electronic door lock
- Medical and healthcare devices
- Handheld devices
- Motor drive
- Elevator calling board
- Gaming and entertainment

This product series is available in LQFP48, LQFP32, QFN32, QFN28 and TSSOP20 packages.

1.2 Key features

- Core and system
 - 32-bit Arm® Cortex®-M0.
 - Frequency up to 72MHz.
- Memory
 - Up to 64KB embedded Flash storage.
 - Up to 8KB SRAM.
 - Embedded Bootloader to support In-System-Programming (ISP).
- Clock, reset and power management
 - Power supply ranges from 2.0 to 5.5V.
 - Power-on and Power-down reset (POR/PDR), Programmable voltage detector

- (PVD).
- 4 to 24MHz high speed crystal oscillator.
- 8MHz factory-trimmed high speed RC oscillator.
- Integrated PLL to generate up to 72MHz system clock and support multiple prescaler rate to provide clock sources to bus matrix and peripherals.
- 40KHz low speed oscillator.
- Low power
 - Multiple low power modes including Sleep mode, Stop mode, Deep Stop mode and Standby mode.
- One DMA controller with 5 channels to support peripherals including timers, ADC, UART, I2C, SPI, and FlexCAN.
- Total 9 timers:
 - One 16-bit 4-channel advanced timer (TIM1), each channel providing two PWM output including one complementary output, supports hardware dead-time insertion and emergency break when fault detected.
 - One 16-bit general purpose timer (TIM3) and one 32-bit general purpose timer (TIM2), with up to four input capture or output compare channels and can be used for infrared decode.
 - Three 16-bit basic timers (TIM14 / TIM16 / TIM17), with one input capture or output compare channel and one complementary output, support hardware dead-time insertion, emergency break when fault detected, and integrated modulator circuit for infrared control.
 - Two watchdog timers, including one independent watchdog (IWDG) and one window watchdog (WWDG).
 - One 24-bit SysTick timer.
- Up to 40 fast I/O ports:
 - All I/O ports can be mapped to 16 external interrupts.
 - All I/O ports can accept input or generate output signal voltage level is not higher than V_{DD} .
- Up to 7 communication interfaces:
 - Three UART.
 - One I2C.
 - Two SPI (support I2S mode).
 - One FlexCAN module supports CAN 2.0B interface.
- One 12-bit Analog-to-Digital converter (ADC), support 1 μ s conversion duration, with up to 13 external inputs and 2 internal inputs
 - Conversion range: 0 to V_{DDA} .
 - Configurable sampling cycles and resolution.
 - On-chip temperature sensor.

Introduction

- On-chip voltage sensor.
- One high speed analog comparator
- 32-bit hardware divider
- Embedded CRC engine
- 96bit unique chip ID (UID)
- Debug mode
 - Serial Wire Debug (SWD).
- Available in LQFP48, LQFP32, QFN32, QFN28 and TSSOP20 packages

2 Ordering information

2.1 Ordering table

Table 2-1 MM32F0140 ordering table 1

Part numbers		MM32 F0141 B4Q	MM32 F0141 C4Q	MM32 F0144 C4Q(V)	MM32 F0141 B4P	MM32 F0141 C4P	MM32 F0144 C4P(V)	MM32 F0141 B6P	MM32 F0141 C6P	MM32 F0144 C6P(V)
CPU frequency		72 MHz								
Flash - KB		32	64	64	32	64	64	32	64	64
SRAM - KB		8	8	8	8	8	8	8	8	8
Timers	16-bit GP	1	1	1	1	1	1	1	1	1
	32-bit GP	1	1	1	1	1	1	1	1	1
	Basic	3	3	3	3	3	3	3	3	3
	Advanced	1	1	1	1	1	1	1	1	1
Interface s	UART	3	3	3	3	3	3	3	3	3
	I2C	1	1	1	1	1	1	1	1	1
	SPI / I2S	2	2	2	2	2	2	2	2	2
	FlexCAN	-	-	1	-	-	1	-	-	1
GPIO		28	28	28	26	26	26	40	40	40
12-bit ADC	Modules	1	1	1	1	1	1	1	1	1
	Channels	13	13	13	13	13	13	13	13	13
Comparator		1	1	1	1	1	1	1	1	1
Supply voltage		2.0V to 5.5V								
Temperature range		-40°C to +85°C / -40°C to +105°C (Suffix V)								
Package		QFN32 5x5 mm2			LQFP32 7x7 mm2			LQFP48 7x7 mm2		

Ordering information

Table 2-2 MM32F0140 ordering table 2

Part numbers		MM32 F0141 B1T	MM32 F0141 C1T	MM32 F0144 C1T(V)	MM32 F0141 B3N	MM32 F0141 C3N	MM32 F0144 C3N(V)
CPU frequency		72 MHz					
Flash - KB		32	64	64	32	64	64
SRAM - KB		8	8	8	8	8	8
Timers	16-bit GP	1	1	1	1	1	1
	32-bit GP	1	1	1	1	1	1
	Basic	3	3	3	3	3	3
	Advanced	1	1	1	1	1	1
Interface s	UART	3	3	3	3	3	3
	I2C	1	1	1	1	1	1
	SPI / I2S	1 (SPI1/I2S1)	1 (SPI1/I2S1)	1 (SPI1/I2S1)	1 (SPI1/I2S1)	1 (SPI1/I2S1)	1 (SPI1/I2S1)
	FlexCAN	-	-	1	-	-	1
GPIO		16	16	16	24	24	24
12-bit ADC	Modules	1	1	1	1	1	1
	Channels	9	9	9	13	13	13
Comparator		1	1	1	1	1	1
Supply voltage		2.0V to 5.5V					
Temperature range		-40°C to +85°C / -40°C to +105°C (Suffix V)					
Package		TSSOP20 4.35x6.45 mm ²			QFN28 4x4 mm ²		

2.2 Marking information

Notes about the marking: The purpose of this section is to guide users to identify the required information from the chip marking, and the format (including font, font size, alignment, etc.), position, proportion, etc. in the marking figures may be different from the actual chip marking, and the marking of some packages may not contain MindMotion logo, such format, position, proportion, logo, etc. information, please refer to the actual chips.

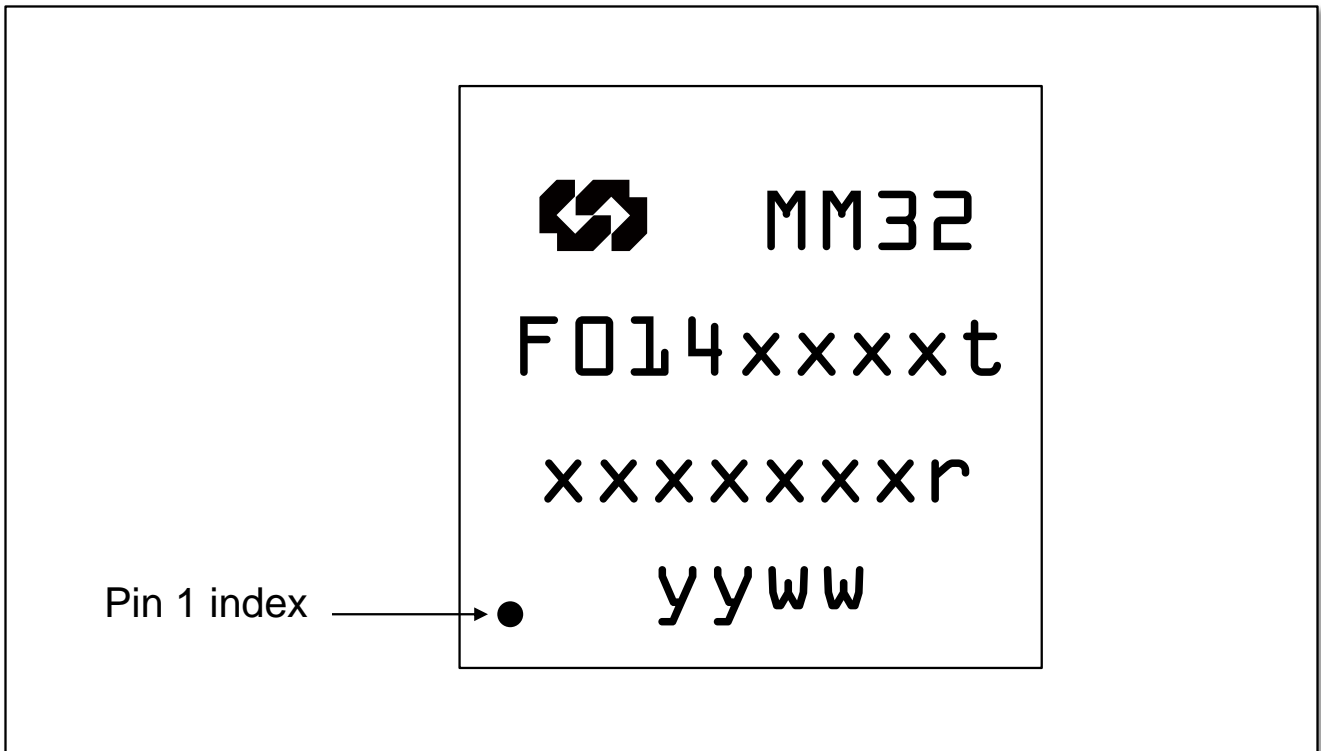

Figure 2-1 LQFP or QFN32 package marking

LQFP or QFN32 package has the following topside marking:

- 1st line: MM32
 - Company logo + first part of product name.
- 2nd line: F014xxxxt
 - Second part of product name, where “t” represents temperature level. “t” = “Empty” means -40 to 85°C (industrial), “t” = “V” means -40 to 105°C (extended industrial).
- 3rd line: xxxxxxxr
 - Trace code + revision code, the “r” means chip revision. For engineering samples, the prefix 2 digital of the Trace code is labelled as “ES”.
- 4th line: yyww
 - Date code, “yy” means year and “ww” means week in date code.

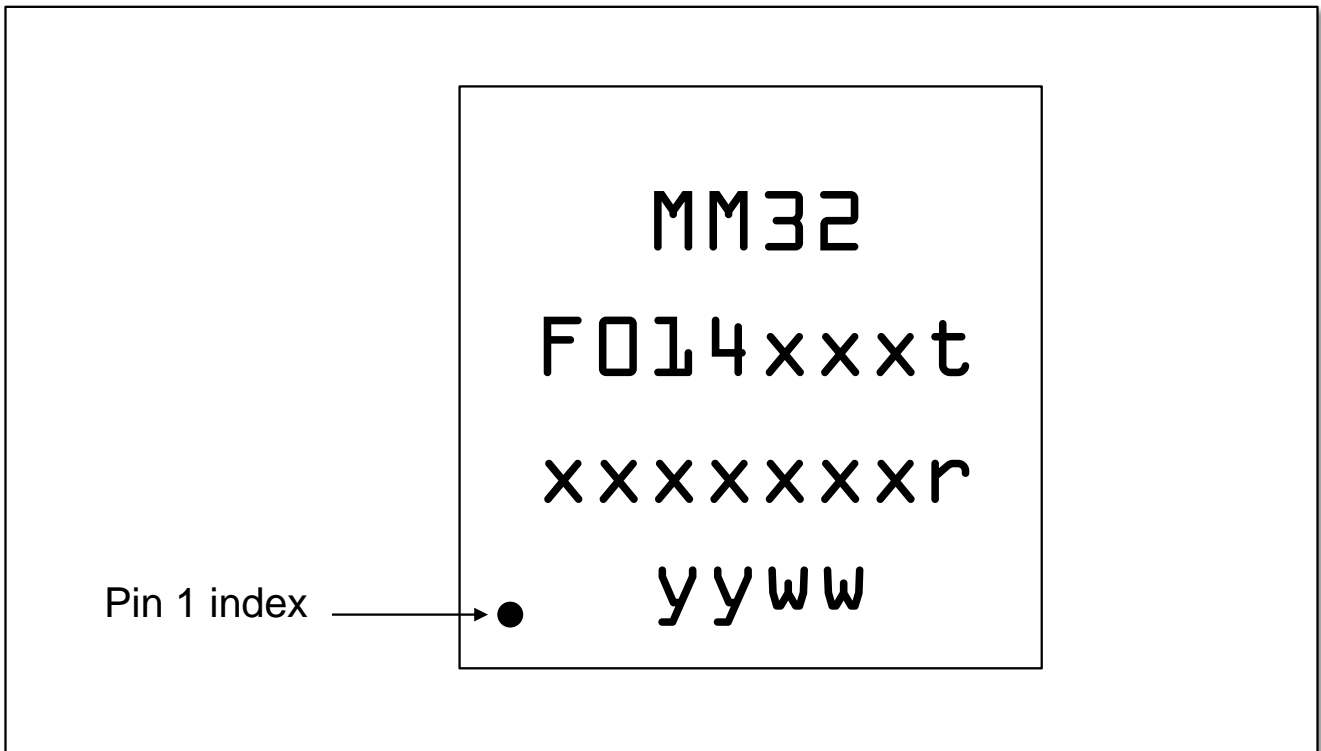

Figure 2-2 QFN28 package marking

QFN28 package has the following topside marking:

- 1st line: MM32
 - Company logo + first part of product name.
- 2nd line: F014xxxxt
 - Part of product name + temperature level, where “t” represents temperature level. “t” = “N” means -40 to 85°C (industrial), “t” = “V” means -40 to -105°C (extended industrial).
- 3rd line: xxxxxxr
 - Trace code + revision code, the “r” means chip revision. For engineering samples, the prefix 2 digital of the Trace code is labelled as “ES”.
- 4th line: yyww
 - Date code, “yy” means year and “ww” means week in date code.

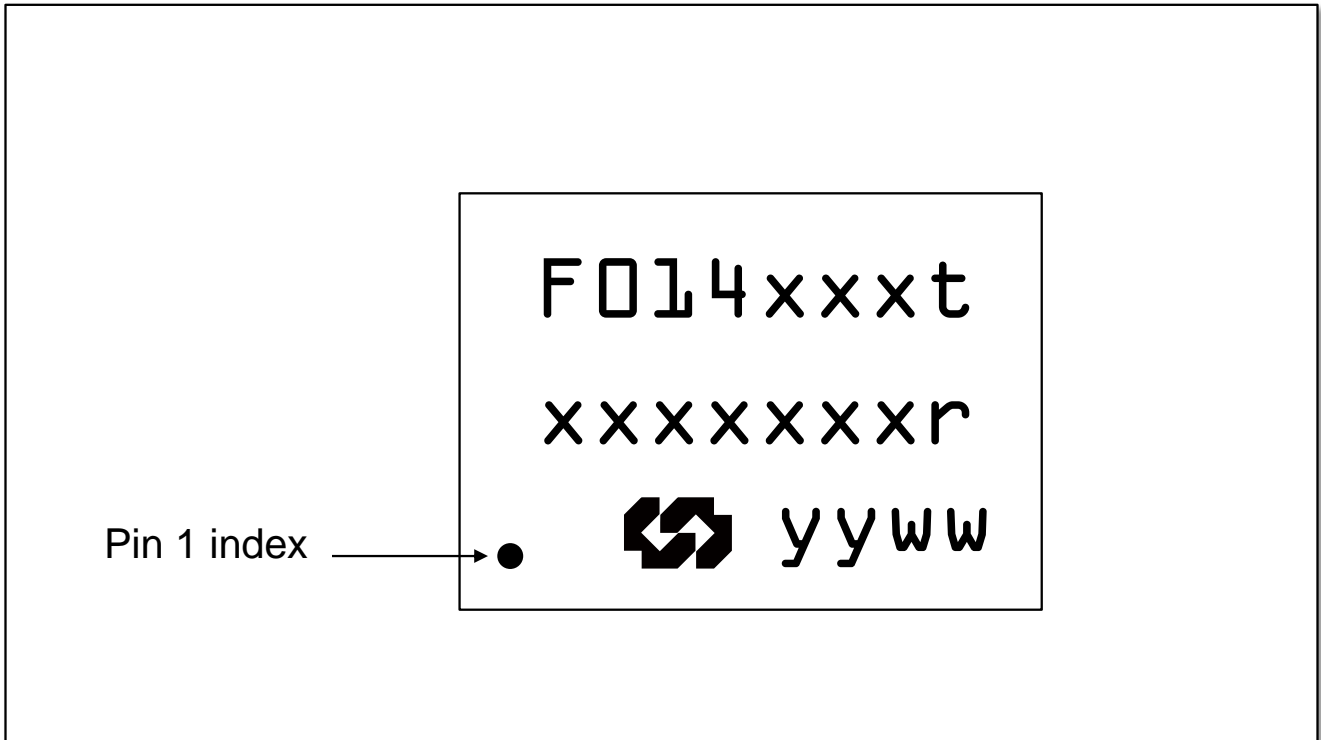

Figure 2-3 TSSOP20 package marking

TSSOP20 package has the following topside marking:

- 1st line: F014xxxt
 - Part of product name + temperature level, where “t” represents temperature level. “t” = “T” means -40 to 85°C (industrial), “t” = “V” means -40 to -105°C (extended industrial).
- 2nd line: xxxxxxr
 - Trace code + revision code, the “r” means chip revision. For engineering samples, the prefix 2 digital of the Trace code is labelled as “ES”.
- 3rd line: Company logo + yyww
 - Date code, “yy” means year and “ww” means week in date code.

2.3 Part identification

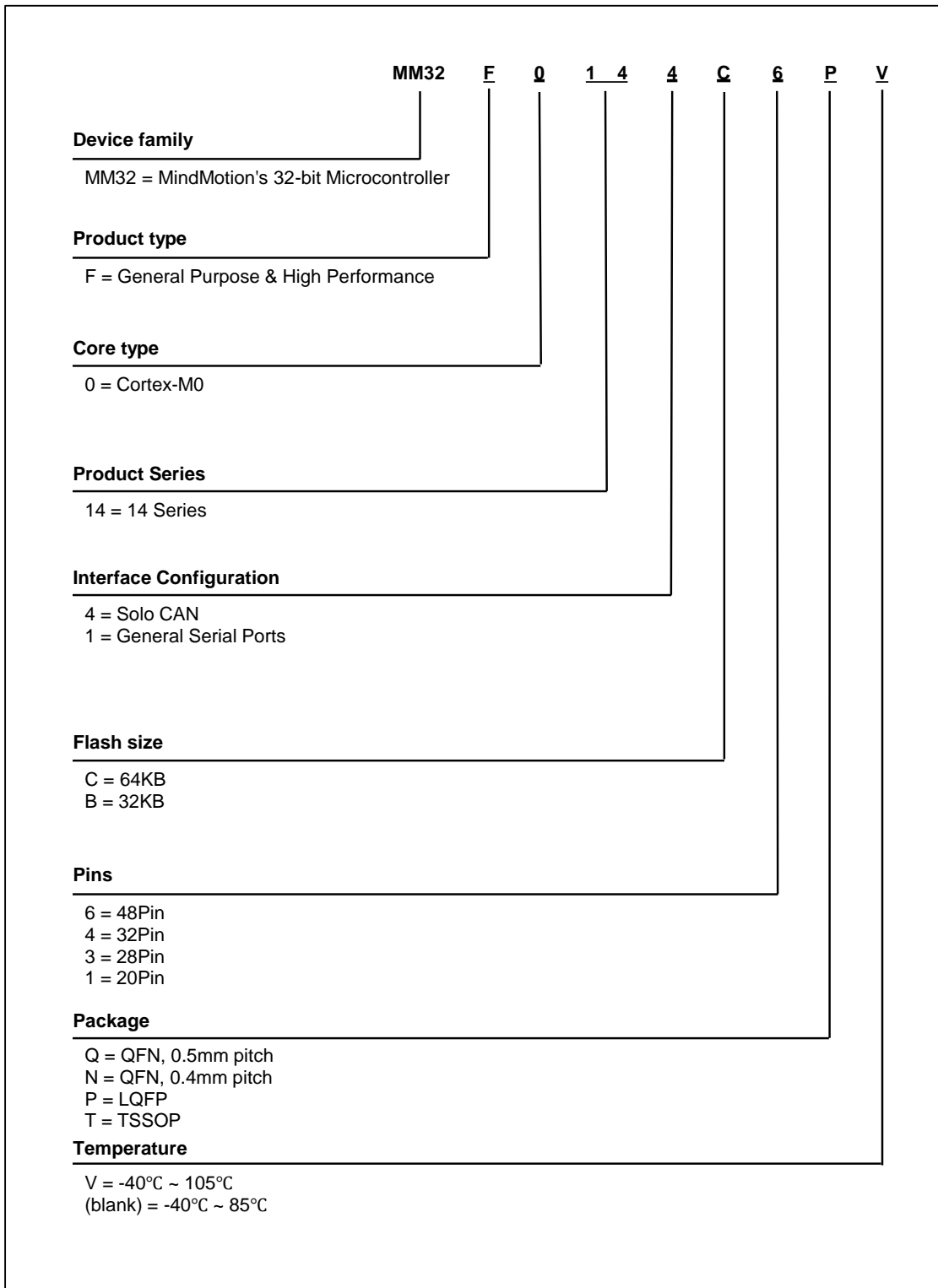

Figure 2-4 Part number naming rule

3 Functional description

3.1 Block diagram

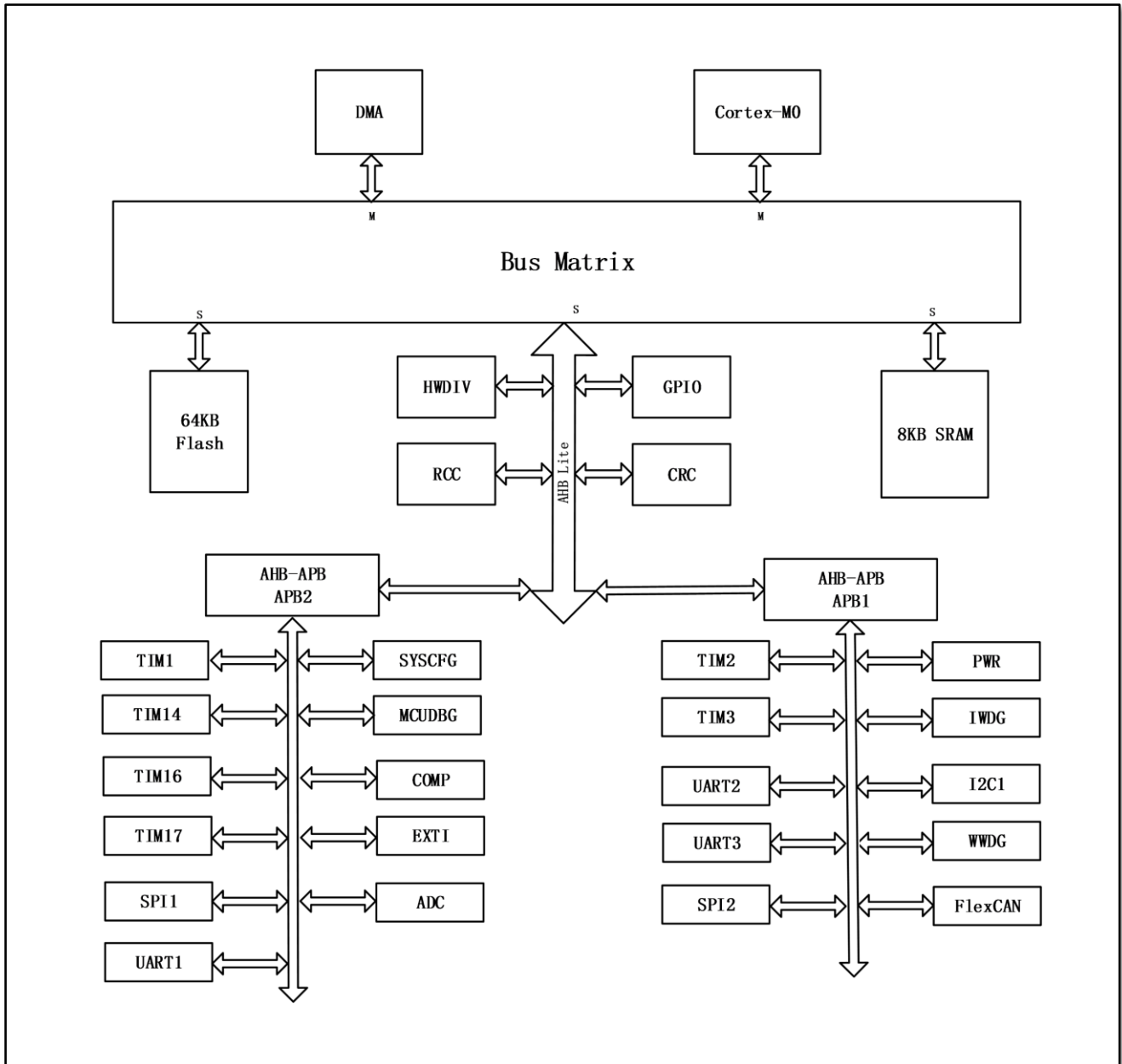

Figure 3-1 System block diagram

3.2 Core introduction

The Arm® Cortex®-M0 processor provides real-time processing and advanced interrupt handling system, which is perfect for cost-effective and low-pin-count microcontrollers targeting real-time control and low power applications.

The Arm® Cortex®-M0 is a 32-bit RISC processor, provides state-of-the-art code efficiency, which is extremely suitable for small memory size microcontrollers and small code size applications.

With its embedded Arm core, this product is compatible with all the tools and software for Arm-based products.

3.3 Bus introduction

The bus matrix includes one AHB inter-connection bus matrix, one AHB bus and two AHB-to-APB bridges. The bus matrix has arbitration capability for scenarios when both CPU and DMA send access simultaneously. The peripherals on the AHB bus (e.g., RCC, HWDIV, GPIO, CRC) are connected to the system bus through the inter-connection matrix. The data are transferred between AHB and APB bus using an AHB-to-APB bridge. When there's 8-bit or 16-bit access to APB registers, the APB bus will extend the access to 32-bit automatically.

3.4 Memory map

Table 3-1 Memory map

Bus	Address range	Size	Peripheral
Flash	0x0000 0000 - 0x0000 FFFF	64 KB	Map to main Flash, system memory or SRAM according to boot configuration
	0x0001 0000 - 0x07FF FFFF	~128 MB	Reserved
	0x0800 0000 - 0x0800 FFFF	64 KB	Main Flash
	0x0801 0000 - 0x1FFD FFFF	~383 MB	Reserved
	0x1FFE 0000 - 0x1FFE 01FF	0.5 KB	Reserved
	0x1FFE 0200 - 0x1FFE 0FFF	3 KB	Reserved
	0x1FFE 1000 - 0x1FFE 11FF	0.5 KB	Encrypted area
	0x1FFE 1200 - 0x1FFE 1BFF	2.5 KB	Encrypted area
	0x1FFE 1C00 - 0x1FFF F3FF	~256 MB	Reserved
	0x1FFF F400 - 0x1FFF F7FF	1 KB	System memory
	0x1FFF F800 - 0x1FFF F9FF	0.5KB	Option bytes
0x1FFF FA00 - 0x1FFF FFFF	1.5KB	Reserved	
SRAM	0x2000 0000 - 0x2000 1FFF	8 KB	SRAM
	0x2000 2000 - 0x2FFF FFFF	~255 MB	Reserved
APB1	0x4000 0000 - 0x4000 03FF	1 KB	TIM2
	0x4000 0400 - 0x4000 07FF	1 KB	TIM3

Functional description

Bus	Address range	Size	Peripheral
	0x4000 0800 - 0x4000 2BFF	9 KB	Reserved
	0x4000 2C00 - 0x4000 2FFF	1 KB	WWDG
	0x4000 3000 - 0x4000 33FF	1 KB	IWDG
	0x4000 3400 - 0x4000 37FF	1 KB	Reserved
	0x4000 3800 - 0x4000 3BFF	1 KB	SPI2
	0x4000 3C00 - 0x4000 43FF	2 KB	Reserved
	0x4000 4400 - 0x4000 47FF	1 KB	UART2
	0x4000 4800 - 0x4000 4BFF	1 KB	UART3
	0x4000 4C00 - 0x4000 53FF	2 KB	Reserved
	0x4000 5400 - 0x4000 57FF	1 KB	I2C1
	0x4000 5800 - 0x4000 6FFF	6 KB	Reserved
	0x4000 7000 - 0x4000 73FF	1 KB	PWR
	0x4000 7400 - 0x4000 83FF	4 KB	Reserved
	0x4000 8400 - 0x4000 87FF	1 KB	Reserved
	0x4000 8800 - 0x4000 BFFF	14 KB	Reserved
	0x4000 C000 - 0x4000 FFFF	16 KB	FlexCAN
APB2	0x4001 0000 - 0x4001 03FF	1 KB	SYSCFG
	0x4001 0400 - 0x4001 07FF	1 KB	EXTI
	0x4001 0800 - 0x4001 23FF	7 KB	Reserved
	0x4001 2400 - 0x4001 27FF	1 KB	ADC
	0x4001 2800 - 0x4001 2BFF	1 KB	Reserved
	0x4001 2C00 - 0x4001 2FFF	1 KB	TIM1
	0x4001 3000 - 0x4001 33FF	1 KB	SPI1
	0x4001 3400 - 0x4001 37FF	1 KB	DBGMCU
	0x4001 3800 - 0x4001 3BFF	1 KB	UART1
	0x4001 3C00 - 0x4001 3FFF	1 KB	COMP
	0x4001 4000 - 0x4001 43FF	1 KB	TIM14
	0x4001 4400 - 0x4001 47FF	1 KB	TIM16
	0x4001 4800 - 0x4001 4BFF	1 KB	TIM17
	0x4001 4C00 - 0x4001 7FFF	13 KB	Reserved
AHB	0x4002 0000 - 0x4002 03FF	1 KB	DMA
	0x4002 0400 - 0x4002 0FFF	3 KB	Reserved
	0x4002 1000 - 0x4002 13FF	1 KB	RCC
	0x4002 1400 - 0x4002 1FFF	3 KB	Reserved
	0x4002 2000 - 0x4002 23FF	1 KB	Flash Interface
	0x4002 2400 - 0x4002 2FFF	3 KB	Reserved
	0x4002 3000 - 0x4002 33FF	1 KB	CRC
	0x4002 3400 - 0x4002 FFFF	47 KB	Reserved

Functional description

Bus	Address range	Size	Peripheral
	0x4003 0000 - 0x4003 03FF	1 KB	HWDIV
	0x4003 0400 - 0x47FF FFFF	~127 MB	Reserved
	0x4800 0000 - 0x4800 03FF	1 KB	GPIOA
	0x4800 0400 - 0x4800 07FF	1 KB	GPIOB
	0x4800 0800 - 0x4800 0BFF	1 KB	GPIOC
	0x4800 0C00 - 0x4800 0FFF	1 KB	GPIOD

3.5 Flash

This product provides up to 64KB embedded Flash memory available for storing code and data.

3.6 SRAM

This product provides up to 8KB embedded SRAM.

3.7 NVIC

This product embeds a Nested vector interrupt controller (NVIC), able to handle multiple maskable interrupt channels (excluding the 16 interrupt lines of the Cortex®-M0) and manage 4 programmable priority levels.

- Tightly coupled NVIC gives low latency interrupt processing.
- Interrupt entry vector table address passed directly to the core.
- Allow early processing of interrupts.
- Support high priority interrupt preemption.
- Support interrupt tail-chaining.
- Automatically save processor status.
- Automatic restoration when the interrupt returns with no instruction overhead.

This module provides flexible interrupt management with minimal interrupt latency.

3.8 EXTI

The external interrupt/event controller (EXTI) contains multiple edge detectors to capture the level changes on the I/O ports and generate interrupt/event to CPU. All I/O ports are connected to 16 external interrupt lines. Each interrupt line can be independently enabled or disabled and configured to select the trigger mode (rising edge, falling edge or both edges). A pending register can save all the interrupt request status.

The EXTI can detect a pulse width shorter than the internal APB2 clock period.

3.9 Clock and boot

The system clock can be configured after chip power-on. After the power-on reset, the default clock is the internal 8MHz high speed oscillator (HSI). User can configure to use the external 4 to 24MHz crystal oscillator (HSE) as the system clock. The system will automatically block the external clock source, turn off the PLL and use the internal oscillator when the external clock is detected to be invalid. Meanwhile, if the clock monitor interrupt is enabled, an interrupt request will be generated.

The clock system uses multiple pre-dividers to generate the clock for the AHB and APB (APB1 and APB2) bus. The maximum frequency of the AHB and APB bus clock can reach up to 72MHz.

3.10 Boot modes

During boot, BOOT0 pin and nBOOT1 bit are used to select one of three boot options:

- Boot from embedded Flash
- Boot from system memory
- Boot from embedded SRAM

The Bootloader code locates in the system memory. Once the chip boots from the system memory, it will run the bootloader code and user can program the embedded Flash through UART1 port by using the bootloader.

3.11 Power supply schemes

- $V_{DD} = 2.0V \sim 5.5V$: I/O ports and internal voltage regulator are powered by the V_{DD} Pins.
- $V_{DDA} = 2.0V \sim 5.5V$: ADC, reset logic, oscillators, PLL are powered by the V_{DDA} pin. V_{DDA} and V_{SSA} can either be connected to V_{DD} and V_{SS} respectively or be powered individually. When powered individually, the power supply should be at the same voltage level as the V_{DD} and V_{SS} .

3.12 Power supply supervisors

This product integrates the power-on reset (POR) and power-down reset (PDR) circuit. This circuit is workable in all power modes, to make sure the chip can work above the lowest power supply voltage. When the V_{DD} is lower than the preset threshold (V_{POR}/V_{PDR}), this circuit will put system to reset status.

This product also integrates a programmable voltage monitor (PVD), it can monitor the V_{DD} and V_{DDA} voltage, and compare it with the preset threshold V_{PVD} . When V_{DD} is lower or higher than V_{PVD} , an interrupt request can be generated, then the interrupt handler can send out warning information or put the chip into safe mode. The PVD function can be configured to be enabled.

3.13 Voltage regulator

The on-chip voltage regulator can regulate the external supply voltage to a lower and stable supply voltage that used by the internal circuits. The voltage regulator is workable after the chip power-on reset (POR).

3.14 Low power mode

This product supports multiple low power modes, user can select the low power modes according to their application to achieve a balance between power consumption, wakeup time and wakeup source.

Sleep mode

In Sleep mode, only the CPU clock is gated off. All peripherals continue to operate and can wake up the CPU when an interrupt/event occurs.

Stop mode

In Stop mode, low power consumption can be achieved with all RAM and registers content in retention. In Stop mode, HSI and HSE are powered off. The microcontroller can be woken up by the EXTI signals. EXTI signals can come from the 16 external I/O ports or PVD output.

Deep Stop mode

Similar as Stop mode, but with lower power consumption.

Standby mode

In Standby mode, the lowest power consumption can be achieved. In this mode, the voltage regulator is powered off, and all the 1.5V domain are shut down. PLL, HSI and HSE are also powered off. Wakeup sources include rising edge on WKUP pin, active reset on NRST pin, IWDG reset. SRAM and registers content are lost in this mode. Only standby circuit are powered.

The peripheral status in each low-power mode is shown in Table 3-2, please note:

- Power Down indicates that the module is powered off and all data except Flash is lost.
- Optional indicates that the peripheral can be turned on or off through software configuration.
- ON means work.
- OFF indicates that the function is turned off.
- Retention indicates that data is retained but not operational.
- High-z represents a high-impedance state.

Functional description

Table 3-2 Peripheral status in different power modes

Module/Mode	Run	Sleep	Stop	Deep Stop	Standby
Max. Freq.	72MHz	72MHz	40KHz	40KHz	40KHz
PVD	Optional	Optional	Optional	Optional	OFF
POR/BOR	ON	ON	ON	ON	ON
CPU	ON	OFF	OFF	OFF	Power Down
SRAM	ON	ON	Retention	Retention	Power Down
Flash	ON	Standby	Standby	Deep Standby	Power Down
HSI	Optional	Optional	OFF	Power Down	Power Down
PLL	Optional	Optional	Power Down	Power Down	Power Down
LSI	Optional	Optional	Optional	Optional	Optional
HSE	Optional	Optional	OFF	OFF	OFF
ADC	Optional	Optional	OFF	OFF	OFF
COMP	Optional	Optional	Optional	Optional	OFF
IWDG	Optional	Optional	Optional	Optional	Optional
Other Peripherals	Optional	Optional	OFF	OFF	Power Down
I/O	Optional	Retention	Retention	Retention	High-z ⁽¹⁾

1. NRST maintains the reset function, wakeup I/O (WKUP) can wake up, other I/Os are high impedance.

3.15 Hardware divider

This product has a hardware divider unit (HWDIV). It can automatically run the 32-bit signed or unsigned integer division operation. The HWDIV is especially useful in some high-performance applications.

3.16 DMA

This product has a 5-channel direct memory access (DMA) controller. The DMA controller can be used to move data from memory to memory, peripherals to memory or memory to peripherals without CPU intervention. The DMA controller support ring buffer mode, when data reaches end of the buffer, the ring buffer mode can avoid generating an interrupt.

Each DMA channel has independent DMA request handling logic. All channels can be triggered by software. For each channel, the data length, source address and destination address can be independently configured by software.

DMA can be used for peripherals include UART, I2C, SPI, ADC, and general purpose, advanced, or basic timers.

3.17 Timers and watchdogs

Functional description

This product has one advanced timer, two general purpose timers, three basic timers, two watchdog timers and one SysTick timer. The table below compares the features of advanced, general purpose and basic timers.

Table 3-3 Feature summary of advanced, general purpose and basic timers

Type	Instance	Resolution	Counter direction	pre-divider	DMA request	Capture/compare channels	Complementary output
Advanced	TIM1	16-bit	up, down, up/down	1 to 65536	Yes	4	3
General purpose	TIM2	32-bit	up, down, up/down	1 to 65536	Yes	4	No
	TIM3	16-bit	up, down, up/down	1 to 65536	Yes	4	No
Basic	TIM14	16-bit	up	1 to 65536	Yes	1	No
	TIM16 / TIM17	16-bit	up	1 to 65536	Yes	1	1

Advanced timer (TIM1)

The advanced timer includes a 16-bit counter, four capture/compare channels and three phases complementary PWM generator. This timer supports hardware dead-time insertion when using as complementary PWM generator. This timer can also be used as a full-function general purpose timer. This timer has four independent channels, each channel can be used for:

- Input capture
- Output compare
- PWM generator (center- or edge-aligned)
- Single pulse output

When this timer is used as a general-purpose timer, it has the same function as the TIM2. When this timer is used as a 16-bit PWM generator, it can be configured to a broad duty cycle range from 0% to 100%.

The advanced timer has lots of identical features and internal structures as the general-purpose timer, in this way the advanced timer can work together with the general-purpose timer through the link function, to provide synchronization and event trigger function.

In debug mode, the counter can be frozen.

General-purpose timer (TIMx)

This product has two general-purpose timers (TIM2, TIM3). The timer has a 16- or 32-bit counter, support both up and down counting, with automatically reload. The timer also has a 16-bit frequency pre-divider and four independent channels. Each channel can be used as input capture, output compare, PWM or single pulse output.

32-bit general-purpose timer

This timer has a 32-bit up and down counter, a 16-bit prescaler and four independent channels, each channel can be used as input capture, output compare, PWM or single

pulse output.

16-bit general-purpose timer

This timer has a 16-bit up and down counter, a 16-bit prescaler and four independent channels, each channel can be used for input capture, output compare, PWM or single pulse output.

These general-purpose timers can also work together through the timer link function, to provide synchronization between timers and event trigger function.

Any general-purpose timer can be used to generate PWM output or work as basic timer. Each timer has independent DMA request.

These timers can also be used to decode incremental encoder signals and can also be used to decode one to four Hall sensors' digital output.

In debug mode, the counter can be frozen.

Basic timer (TIM14 / TIM16 / TIM17)

This product has three basic timers (TIM14 / TIM16 / TIM17), each timer has a 16-bit counter, supports automatic reload, and only supports up-counting. The timer has a 16-bit prescaler and one independent channel, each channel can be used as input capture, output compare, PWM or single pulse output. When used in PWM mode, TIM14 has no complementary output port, TIM16 and TIM17 are equipped with complementary output port, which can generate complementary PWM pairs and support hardware dead-timer insertion.

Independent watchdog (IWDG)

The independent watchdog is based on a 12-bit down counter and an 8-bit prescaler. It is clocked by an internal independent 40KHz oscillator. As it is independent of the main clock, it can run in Stop and Standby modes. It can be used to reset the entire system when a system error occurs or as a free timer to provide timeout management for applications. It can be configured to start the watchdog by software or hardware through the option byte. In debug mode, the counter can be frozen.

Window watchdog (WWDG)

The window watchdog is based on a 7-bit down counter that can be set as free-running. It can be used as a watchdog to reset the entire system when an system error occurs. It is clocked by the main clock and has an early warning interrupt function; in debug mode, the counter can be frozen.

System tick timer (Systick)

This timer is dedicated to the real-time operating system and can also be used as a general down counter. It has the following features:

- 24-bit down counter
- Auto-reload capability
- A maskable interrupt can be generated when counter value is 0

- Programmable clock source

3.18 GPIO

Each GPIO pin can be configured by software as output (push-pull or open-drain), input (with or without pull-up or pull-down) or multiplexed peripherals function port. Most GPIO pins are shared with digital or analog functions. If necessary, the peripheral functions of the I/O pins can be locked by specific operation to avoid accidental writing to the I/O register.

3.19 UART

This product has up to three UART interfaces. The UART interface supports configurable data length of 5-, 6-, 7-, 8-, and 9-bits. The UART interface also supports LIN master and slave function and ISO7816 smart card mode. All UART interfaces support DMA operation.

3.20 I2C

This product has up to one I2C interface. The I2C bus interface can work in multi-master mode or slave mode and supports standard and fast mode. The I2C interface supports 7-bit or 10-bit addressing.

3.21 SPI

This product has up to two SPI interfaces. The SPI interface can be configured as 1 to 32 bits per frame in master or slave mode, allowing up to 36 Mbps in master mode and 18 Mbps in slave mode. All SPI interfaces support DMA operation.

3.22 I2S

This product has up to two I2S interfaces shared with the SPI module. The I2S module shares three pins with SPI, supports half-duplex communication (transmitter or receiver only), master or slave operation, underflow flag in transmit mode (only slave), and overflow flag in receive mode (master and slave mode) and frame error flag in receive and transmit mode (only slave). 8-bit programmable linear prescaler is used to achieve precise audio sampling frequency from 8KHz to 192KHz. The data format can be 16-bit, 24-bit or 32-bit, and the data packet frame is fixed at 16-bit (16-bit data frame) or 32-bit (16-bit, 24-bit or 32-bit data frame).

3.23 FlexCAN

This product has up to one FlexCAN interface. The FlexCAN interface is compatible with CAN 2.0A and 2.0B (active) standard, with bit rate up to 1Mbps. It can receive and send standard frames with 11-bit identifiers, as well as extended frames with 29-bit identifiers.

3.24 ADC

This product has one 12-bit analog/digital converter (ADC), with up to 13 external channels available, supports single-shot single-cycle and continuous scan conversion. In the scan mode, the conversion of the sampling value on the selected group of analog inputs is automatically performed. The ADC supports DMA operation.

The analog watchdog function allows the application to monitor one or all selected channels. When the monitored signal exceeds a preset threshold, an interrupt will be generated. The triggers generated by the general-purpose timers (TIMx) and the advanced timers can be selected to trigger the ADC sampling, in this way the ADC sampling can be synchronized with the timer.

Temperature sensor

The temperature sensor can generate a voltage that varies linearly with temperature. The temperature sensor is internally connected to the input channel of the ADC to convert the output of the sensor to a digital value.

3.25 COMP

This product has one build-in analog comparators (COMP), which can be used independently (applicable to all I/O ports that have comparator function) or combined with timers. The COMP module can be used for a variety of functions including low-power mode wake-up event triggered by analog input, fast PWM output break when over-current detected, events capture and OCref-clr events used for cycle-by-cycle current control. The COMP module supports programmable hysteresis voltage, programmable rate and power consumption, rail-to-rail comparator. Each comparator can select the voltage reference from the I/O ports or the internal voltage reference (CRV) which is a divided voltage value of the V_{DDA} or internal bandgap voltage.

3.26 CRC

The cyclic redundancy check (CRC) module uses a fixed polynomial generator to generate a CRC code from a 32-bit data word. Among many applications, CRC is used to verify the consistency of data transmission or storage. Within the scope of the EN/IEC60335-1 standard, it provides a method to detect flash memory errors. The CRC module can be used to calculate the signature of the software package in real time and compare it with the signature generated when the software is linked and generated.

3.27 SWD

This product equips Arm standard Serial Wire Debug (SWD).

4 Pinout and assignment

4.1 Pinout diagram

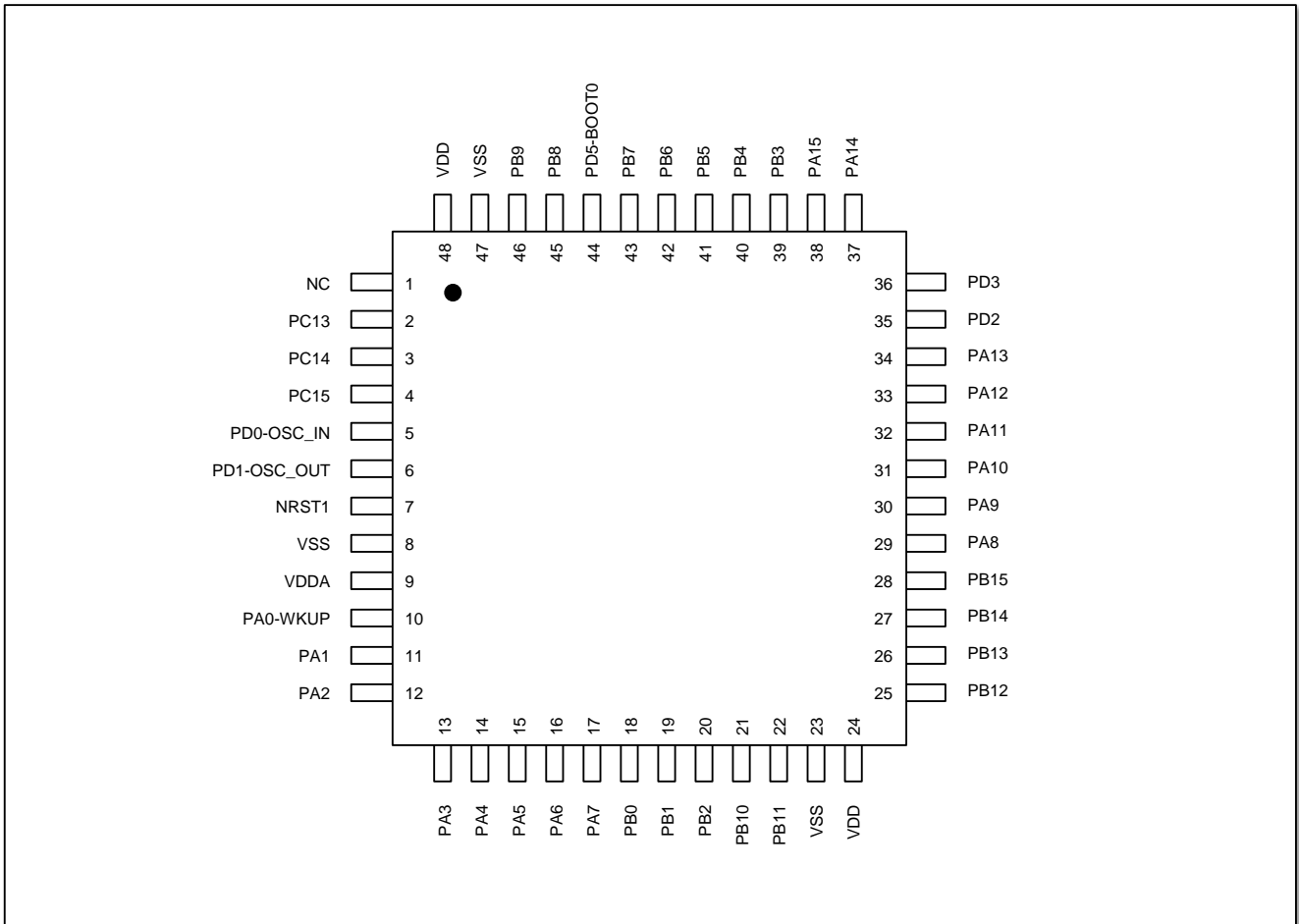

Figure 4-1 LQFP48 pinout diagram

Pinout and assignment

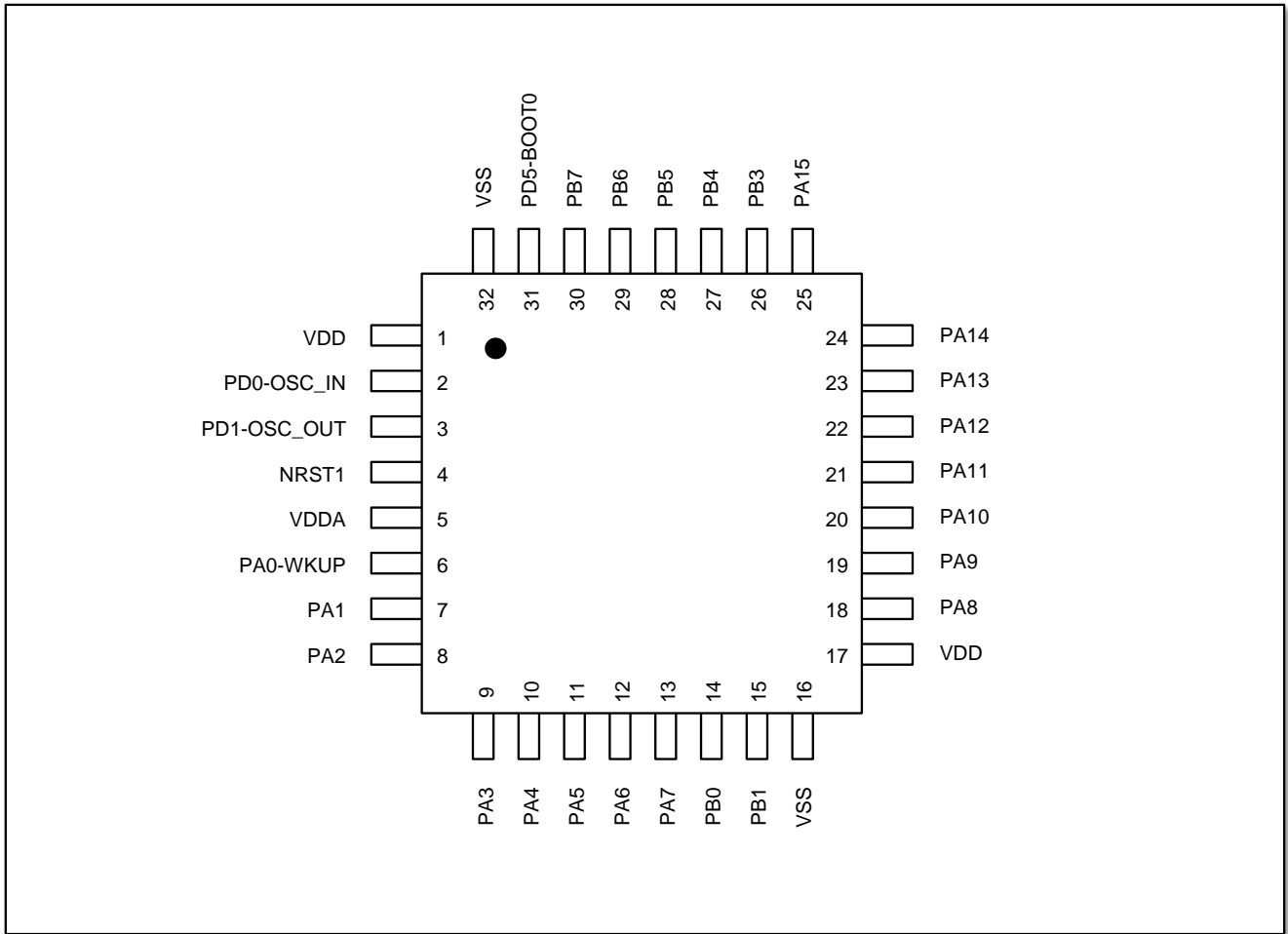

Figure 4-2 LQFP32 pinout diagram

Pinout and assignment

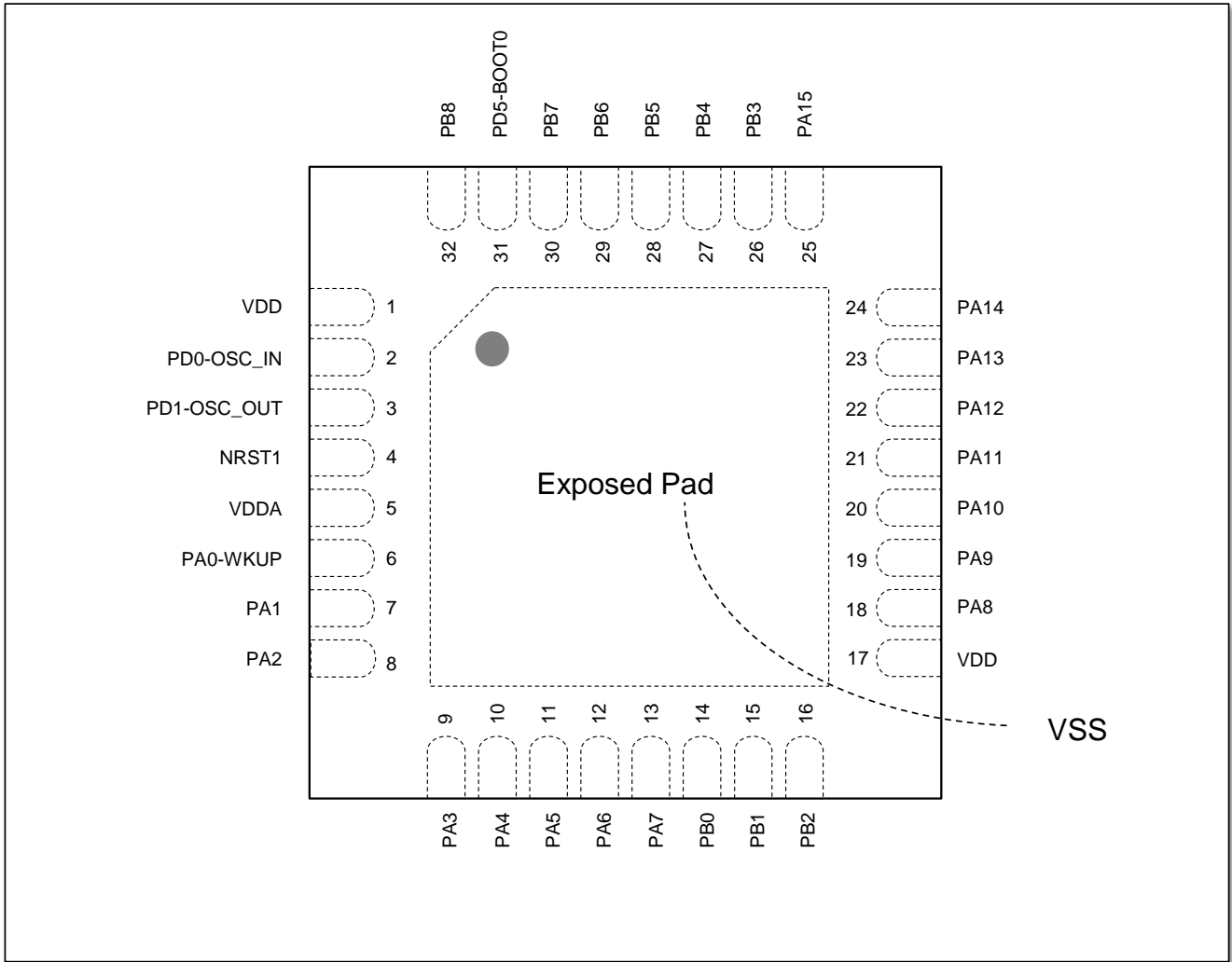

Figure 4-3 QFN32 pinout diagram

Pinout and assignment

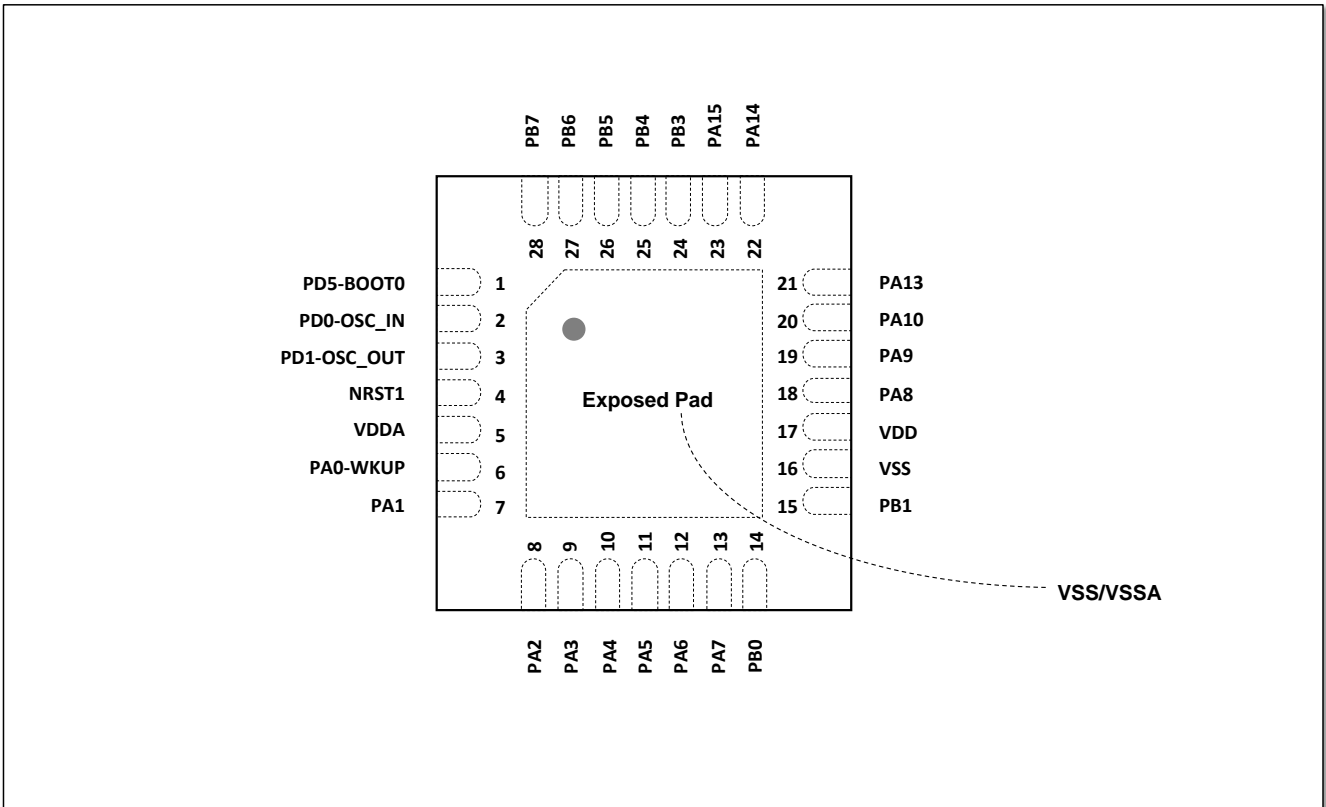

Figure 4-4 QFN28 pinout diagram

Pinout and assignment

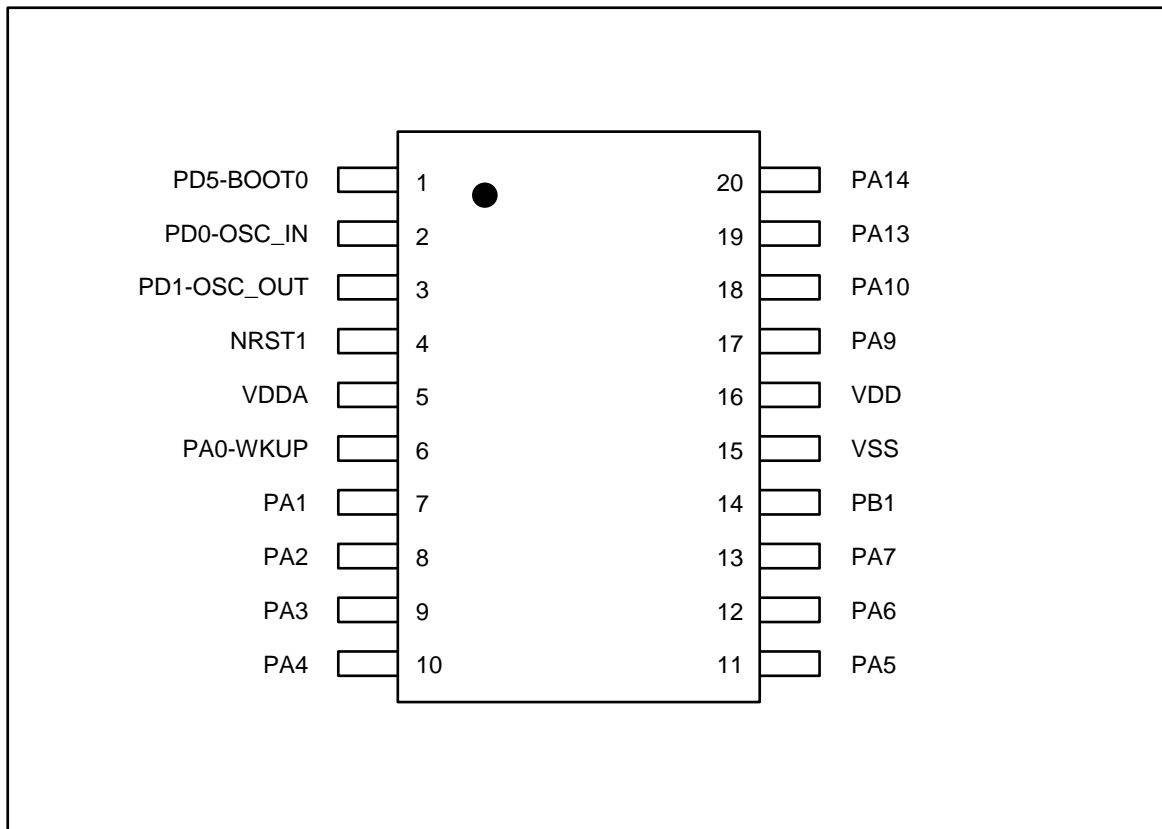

Figure 4-5 TSSOP20 pinout diagram

4.2 Pin assignment

Table 4-1 Pin assignment table

LQFP48	LQFP32	QFN32	QFN28	TSSOP20	Name	Type ⁽¹⁾	I/O level ⁽²⁾	Main function	Multiplex function	Additional function
1	-	-	-	-	NC	-	-	-	-	-
2	-	-	-	-	PC13	I/O	TC	PC13	TIM2_CH1	-
3	-	-	-	-	PC14	I/O	TC	PC14	TIM2_CH2	-
4	-	-	-	-	PC15	I/O	TC	PC15	TIM2_CH3	-
5	2	2	2	2	PD0 OSC_IN	I/O	TC	PD0	UART3_TX I2C_SDA	-
6	3	3	3	3	PD1 OSC_OUT	I/O	TC	PD1	UART3_RX I2C_SCL	-
7	4	4	4	4	NRST1	I/O	-	NRST1	-	-
8	-	-	-	-	VSS	S	-	VSS	-	-
9	5	5	5	5	VDDA	S	-	VDDA	-	-
10	6	6	6	6	PA0 WKUP	I/O	TC	PA0	UART2_CTS TIM2_CH1/TIM2_ETR SPI2_NSS/I2S2_WS TIM2_CH3 COMP1_OUT	ADC1_VIN[0]
11	7	7	7	7	PA1	I/O	TC	PA1	UART2_RTS TIM2_CH2	ADC1_VIN[1] COMP_INP[0]
12	8	8	8	8	PA2	I/O	TC	PA2	UART2_TX TIM2_CH3 SPI2_NSS/I2S2_WS	ADC1_VIN[2] COMP_INP[1]
13	9	9	9	9	PA3	I/O	TC	PA3	UART2_RX TIM2_CH4	ADC1_VIN[3] COMP_INP[2]
14	10	10	10	10	PA4	I/O	TC	PA4	SPI1_NSS/I2S1_WS TIM1_BKIN TIM14_CH1 I2C_SDA	ADC1_VIN[4] COMP_INP[3]
15	11	11	11	11	PA5	I/O	TC	PA5	SPI1_SCK/I2S1_CK TIM2_CH1/TIM2_ETR TIM1_ETR I2C_SCL TIM1_CH3N	ADC1_VIN[5] COMP_INM[0]
16	12	12	12	12	PA6	I/O	TC	PA6	SPI1_MISO/I2S1_MCK TIM3_CH1 TIM1_BKIN UART2_RX TIM1_ETR TIM16_CH1 TIM1_CH3 COMP1_OUT	ADC1_VIN[6] COMP_INM[1]
17	13	13	13	13	PA7	I/O	TC	PA7	SPI1_MOSI/I2S1_SD TIM3_CH2 TIM1_CH1N TIM14_CH1 TIM17_CH1 TIM1_CH2N TIM1_CH3N	ADC1_VIN[7] COMP_INM[2]
18	14	14	14	-	PB0	I/O	TC	PB0	TIM3_CH3 TIM1_CH2N TIM1_CH1N TIM1_CH3	ADC1_VIN[8]
19	15	15	15	14	PB1	I/O	TC	PB1	TIM14_CH1 TIM3_CH4 TIM1_CH3N TIM1_CH4 TIM1_CH2N MCO TIM1_CH2 TIM1_CH1N	ADC1_VIN[9]
20	-	16	-	-	PB2	I/O	TC	PB2	-	-

Pinout and assignment

LQFP48	LQFP32	QFN32	QFN28	TSSOP20	Name	Type ⁽¹⁾	I/O level ⁽²⁾	Main function	Multiplex function	Additional function
21	-	-	-	-	PB10	I/O	TC	PB10	I2C_SCL TIM2_CH3 UART3_TX SPI2_SCK/I2S2_CK	-
22	-	-	-	-	PB11	I/O	TC	PB11	I2C_SDA TIM2_CH4 UART3_RX	-
23	16	-	16	15	VSS	S	-	VSS	-	-
24	17	17	17	16	VDD	S	-	VDD	-	-
25	-	-	-	-	PB12	I/O	TC	PB12	SPI2_NSS/I2S2_WS SPI2_SCK/I2S2_CK TIM1_BKIN SPI2_MOSI/I2S2_SD SPI2_MISO/I2S2_MCK	-
26	-	-	-	-	PB13	I/O	TC	PB13	SPI2_SCK/I2S2_CK SPI2_MISO/I2S2_MCK TIM1_CH1N SPI2_NSS/I2S2_WS SPI2_MOSI/I2S2_SD I2C_SCL TIM1_CH3N TIM2_CH1 UART3_CTS	-
27	-	-	-	-	PB14	I/O	TC	PB14	SPI2_MISO/I2S2_MCK SPI2_MOSI/I2S2_SD TIM1_CH2N SPI2_SCK/I2S2_CK SPI2_NSS/I2S2_WS I2C_SDA TIM1_CH3 TIM1_CH1 UART3_RTS	-
28	-	-	-	-	PB15	I/O	TC	PB15	SPI2_MOSI/I2S2_SD SPI2_NSS/I2S2_WS TIM1_CH3N SPI2_MISO/I2S2_MCK SPI2_SCK/I2S2_CK TIM1_CH2N TIM1_CH2	-
29	18	18	18	-	PA8	I/O	TC	PA8	MCO TIM1_CH1 TIM1_CH2 TIM1_CH3	-
30	19	19	19	17	PA9	I/O	TC	PA9	UART1_TX TIM1_CH2 UART1_RX I2C_SCL MCO TIM1_CH1N TIM1_CH4 CAN_RX	-
31	20	20	20	18	PA10	I/O	TC	PA10	TIM17_BKIN UART1_RX TIM1_CH3 UART1_TX I2C_SDA TIM1_CH1 SPI2_SCK/I2S2_CK CAN_TX	-
32	21	21	-	-	PA11	I/O	TC	PA11	UART3_TX UART1_CTS TIM1_CH4 CAN_RX SPI2_MOSI/I2S2_SD I2C_SCL COMP1_OUT	-

Pinout and assignment

LQFP48	LQFP32	QFN32	QFN28	TSSOP20	Name	Type ⁽¹⁾	I/O level ⁽²⁾	Main function	Multiplex function	Additional function
33	22	22	-	-	PA12	I/O	TC	PA12	UART3_RX UART1_RTS TIM1_ETR CAN_TX SPI2_MISO/I2S2_MCK I2C_SDA TIM1_CH2	-
34	23	23	21	19	PA13	I/O	TC	PA13	SWDIO UART1_TX SPI2_MISO/I2S2_MCK MCO TIM1_CH2 TIM1_BKIN	-
35	-	-	-	-	PD2	I/O	TC	PD2	-	-
36	-	-	-	-	PD3	I/O	TC	PD3	-	-
37	24	24	22	20	PA14	I/O	TC	PA14	SWDCLK UART2_TX UART1_RX SPI1_NSS/I2S1_WS	-
38	25	25	23	-	PA15	I/O	TC	PA15	SPI1_NSS/I2S1_WS UART2_RX TIM2_CH1/TIM2_ETR	-
39	26	26	24	-	PB3	I/O	TC	PB3	SPI1_SCK/I2S1_CK TIM2_CH2 UART1_TX TIM2_CH3 TIM1_CH1 TIM2_CH1	ADC1_VIN[10]
40	27	27	25	-	PB4	I/O	TC	PB4	SPI1_MISO/I2S1_MCK TIM3_CH1 UART1_RX TIM17_BKIN TIM1_CH2 TIM2_CH2	ADC1_VIN[11]
41	28	28	26	-	PB5	I/O	TC	PB5	SPI1_MOSI/I2S1_SD TIM3_CH2 TIM16_BKIN MCO TIM1_CH3 TIM2_CH3	-
42	29	29	27	-	PB6	I/O	TC	PB6	UART1_TX I2C_SCL TIM16_CH1N TIM2_CH1	-
43	30	30	28	-	PB7	I/O	TC	PB7	UART1_RX I2C_SDA TIM17_CH1N UART2_TX	ADC1_VIN[12]
44	31	31	1	1	PD5 BOOT0	I/O	TC	PD5	-	-
45	-	32	-	-	PB8	I/O	TC	PB8	I2C_SCL TIM16_CH1 CAN_RX UART2_RX	-
46	-	-	-	-	PB9	I/O	TC	PB9	I2C_SDA TIM17_CH1 CAN_TX TIM1_CH4 SPI2_NSS/I2S2_WS	-
47	32	-	-	-	VSS	S	-	VSS	-	-
48	1	1	-	-	VDD	S	-	VDD	-	-

1. I = input, O = output, S = power pins, HiZ = high resistance state.
2. TC: standard IO. Input signal level should not exceed VDD.

4.3 Pin multiplexing

Table 4-2 PA port multiplexing AF0-AF8

Pin	AF0	AF1	AF2	AF3	AF4	AF5	AF6	AF7	AF8
PA0	-	UART2_CTS	TIM2_CH1/TIM2_ETR	SPI2_NSS/I2S2_WS	TIM2_CH3	-	-	COMP1_OUT	-
PA1	-	UART2_RTS	TIM2_CH2	-	-	-	-	-	-
PA2	-	UART2_TX	TIM2_CH3	SPI2_NSS/I2S2_WS	-	-	-	-	-
PA3	-	UART2_RX	TIM2_CH4	-	-	-	-	-	-
PA4	SPI1_NSS/I2S1_WS	-	-	TIM1_BKIN	TIM14_CH1	I2C_SDA	-	-	-
PA5	SPI1_SCK/I2S1_CK	-	TIM2_CH1/TIM2_ETR	TIM1_ETR	-	I2C_SCL	TIM1_CH3N	-	-
PA6	SPI1_MISO/I2S1_MCK	TIM3_CH1	TIM1_BKIN	UART2_RX	TIM1_ETR	TIM16_CH1	TIM1_CH3	COMP1_OUT	-
PA7	SPI1_MOSI/I2S1_SD	TIM3_CH2	TIM1_CH1N	-	TIM14_CH1	TIM17_CH1	TIM1_CH2N	TIM1_CH3N	-
PA8	MCO	-	TIM1_CH1	-	-	-	TIM1_CH2	TIM1_CH3	-
PA9	-	UART1_TX	TIM1_CH2	UART1_RX	I2C_SCL	MCO	TIM1_CH1N	TIM1_CH4	CAN_RX
PA10	TIM17_BKIN	UART1_RX	TIM1_CH3	UART1_TX	I2C_SDA	-	TIM1_CH1	SPI2_SCK/I2S2_CK	CAN_TX
PA11	UART3_TX	UART1_CTS	TIM1_CH4	CAN_RX	SPI2_MOSI/I2S2_SD	I2C_SCL	-	COMP1_OUT	-
PA12	UART3_RX	UART1_RTS	TIM1_ETR	CAN_TX	SPI2_MISO/I2S2_MCK	I2C_SDA	-	TIM1_CH2	-
PA13	SWDIO	-	UART1_TX	-	SPI2_MISO/I2S2_MCK	MCO	TIM1_CH2	TIM1_BKIN	-
PA14	SWDCLK	UART2_TX	UART1_RX	SPI1_NSS/I2S1_WS	-	-	-	-	-
PA15	SPI1_NSS/I2S1_WS	UART2_RX	TIM2_CH1/TIM2_ETR	-	-	-	-	-	-

Pinout and assignment

Table 4-3 PB port multiplexing AF0-AF8

Pin	AF0	AF1	AF2	AF3	AF4	AF5	AF6	AF7	AF8
PB0	-	TIM3_CH3	TIM1_CH2N	TIM1_CH1N	TIM1_CH3	-	-	-	-
PB1	TIM14_CH1	TIM3_CH4	TIM1_CH3N	TIM1_CH4	TIM1_CH2N	MCO	TIM1_CH2	TIM1_CH1N	-
PB2	-	-	-	-	-	-	-	-	-
PB3	SPI1_SCK/I2S1_CK	-	TIM2_CH2	UART1_TX	TIM2_CH3	-	TIM1_CH1	TIM2_CH1	-
PB4	SPI1_MISO/I2S1_MCK	TIM3_CH1	-	UART1_RX	-	TIM17_BKIN	TIM1_CH2	TIM2_CH2	-
PB5	SPI1_MOSI/I2S1_SD	TIM3_CH2	TIM16_BKIN	MCO	-	-	TIM1_CH3	TIM2_CH3	-
PB6	UART1_TX	I2C_SCL	TIM16_CH1N	-	TIM2_CH1	-	-	-	-
PB7	UART1_RX	I2C_SDA	TIM17_CH1N	-	UART2_TX	-	-	-	-
PB8	-	I2C_SCL	TIM16_CH1	CAN_RX	UART2_RX	-	-	-	-
PB9	-	I2C_SDA	TIM17_CH1	CAN_TX	TIM1_CH4	SPI2_NSS/I2S2_WS	-	-	-
PB10	-	I2C_SCL	TIM2_CH3	-	UART3_TX	SPI2_SCK/I2S2_CK	-	-	-
PB11	-	I2C_SDA	TIM2_CH4	-	UART3_RX	-	-	-	-
PB12	SPI2_NSS/I2S2_WS	SPI2_SCK/I2S2_CK	TIM1_BKIN	SPI2_MOSI/I2S2_SD	SPI2_MISO/I2S2_MCK	-	-	-	-
PB13	SPI2_SCK/I2S2_CK	SPI2_MISO/I2S2_MCK	TIM1_CH1N	SPI2_NSS/I2S2_WS	SPI2_MOSI/I2S2_SD	I2C_SCL	TIM1_CH3N	TIM2_CH1	UART3_CTS
PB14	SPI2_MISO/I2S2_MCK	SPI2_MOSI/I2S2_SD	TIM1_CH2N	SPI2_SCK/I2S2_CK	SPI2_NSS/I2S2_WS	I2C_SDA	TIM1_CH3	TIM1_CH1	UART3_RTS
PB15	SPI2_MOSI/I2S2_SD	SPI2_NSS/I2S2_WS	TIM1_CH3N	SPI2_MISO/I2S2_MCK	SPI2_SCK/I2S2_CK	-	TIM1_CH2N	TIM1_CH2	-

Pinout and assignment

Table 4-4 PC port multiplexing AF0-AF8

Pin	AF0	AF1	AF2	AF3	AF4	AF5	AF6	AF7	AF8
PC13	-	-	-	-	-	-	TIM2_CH1	-	-
PC14	-	-	-	-	-	-	TIM2_CH2	-	-
PC15	-	-	-	-	-	-	TIM2_CH3	-	-

Pinout and assignment

Table 4-5 PD port multiplexing AF0-AF8

Pin	AF0	AF1	AF2	AF3	AF4	AF5	AF6	AF7	AF8
PD0	UART3_TX	I2C_SDA	-	-	-	-	-	-	-
PD1	UART3_RX	I2C_SCL	-	-	-	-	-	-	-
PD2	-	-	-	-	-	-	-	-	-
PD3	-	-	-	-	-	-	-	-	-
PD5	-	-	-	-	-	-	-	-	-

5 Electrical characteristics

5.1 Test condition

All voltages are referenced to V_{SS} unless otherwise stated.

5.1.1 Load capacitor

The load conditions for pin parameters measurement are shown in the Figure 5-1.

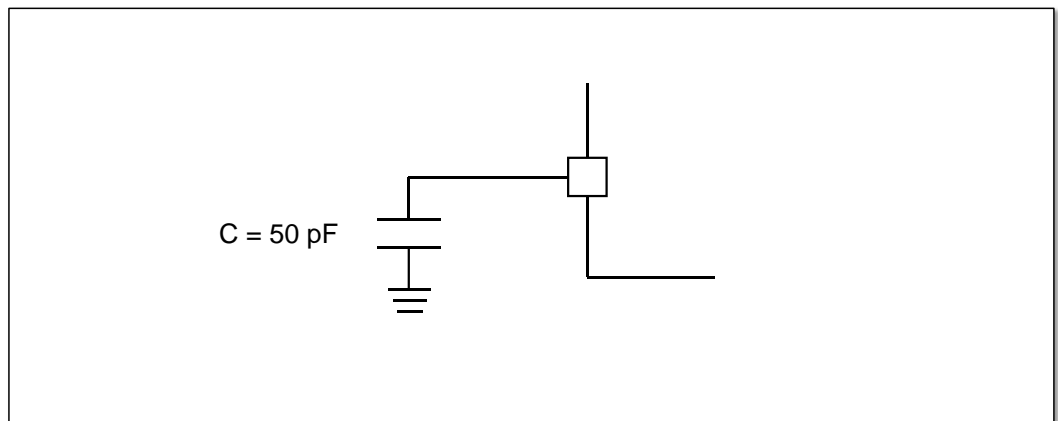

Figure 5-1 Load condition of the pin

5.1.2 Pin input voltage

The measurement of the input voltage on the pin is shown in Figure 5-2.

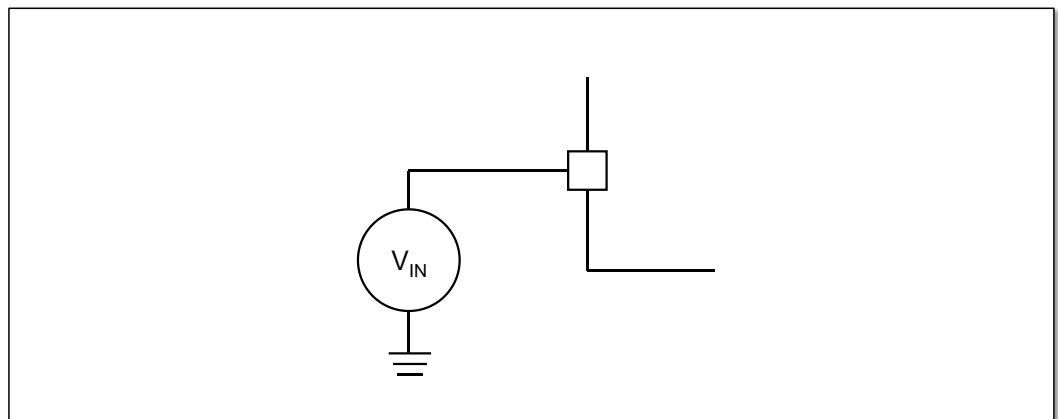

Figure 5-2 Pin input voltage

5.1.3 Power scheme

The power supply design scheme is shown in Figure 5-3.

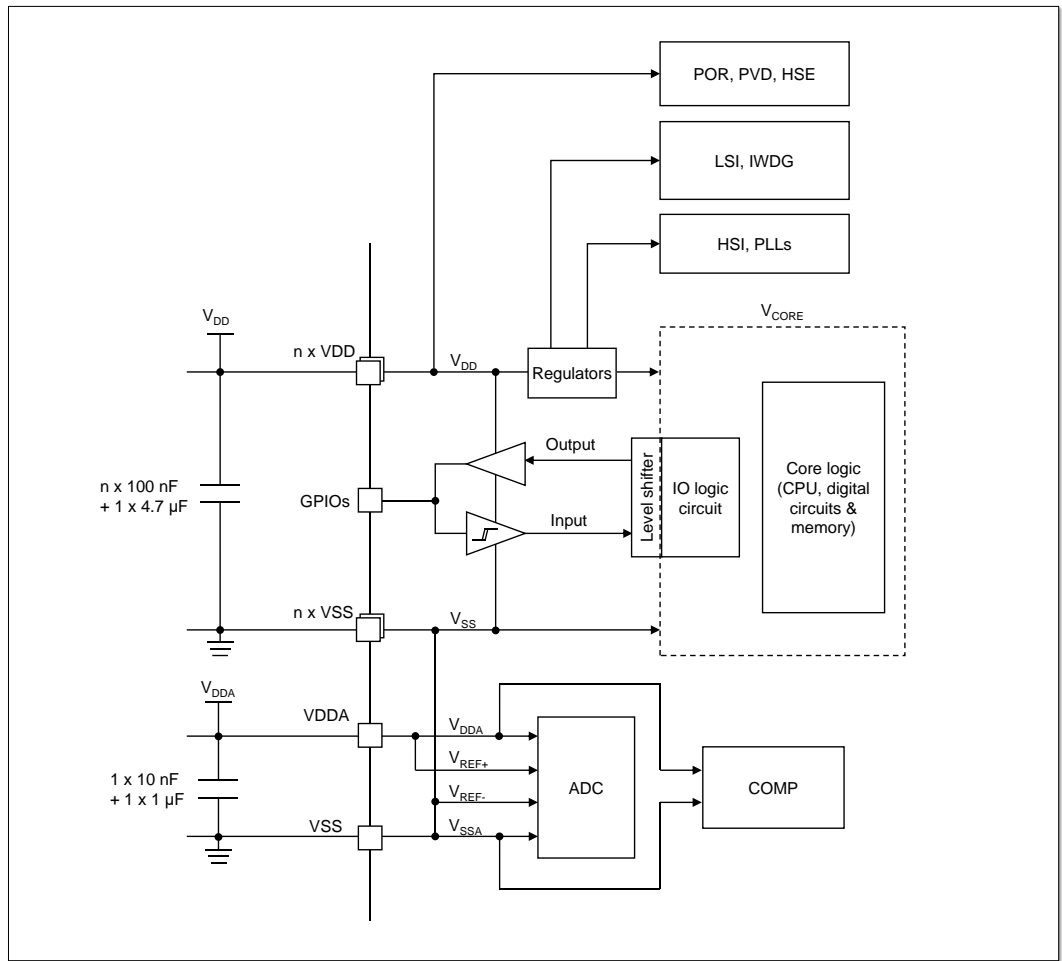

Figure 5-3 Power scheme

5.1.4 Current consumption measurement

The measurement of the current consumption on the pin is shown in Figure 5-4.

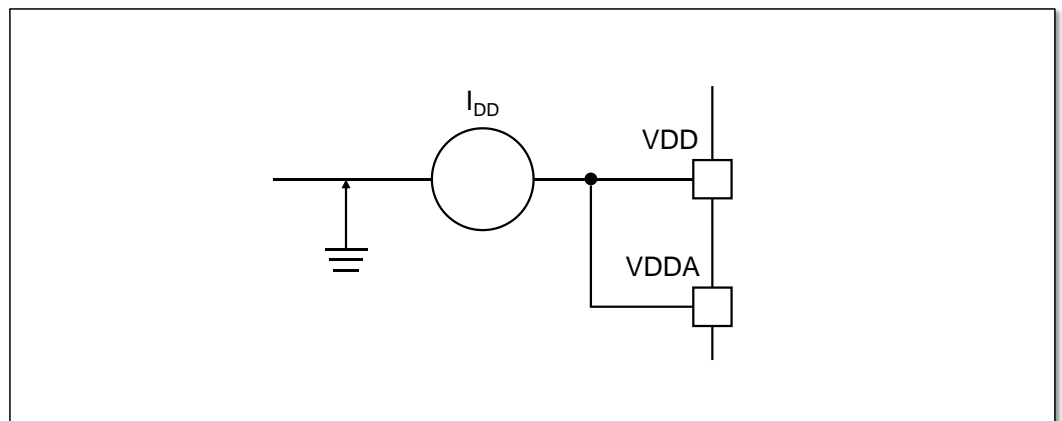

Figure 5-4 Current consumption measurement scheme

5.2 Absolute maximum rating

Electrical characteristics

Stresses above the absolute maximum ratings given in "Absolute Group Maximum Ratings" list (Table 5-1, Table 5-2 and Table 5-3) may cause permanent damage to the device. These are stress ratings only and functional operation of the device at these conditions is not implied. Exposure to maximum rating conditions for extended periods may affect device reliability.

Table 5-1 Voltage characteristics

Symbol	Description	Minimum	Maximum	Unit
$V_{DDx}-V_{SSx}$	External main supply voltage (including V_{DDA} and V_{SSA}) ⁽¹⁾	-0.3	5.8	V
V_{IN} ⁽²⁾	Input voltage on other pins	$V_{SS}-0.3$	$V_{DD}+0.3$	

1. All power (V_{DD} , V_{DDA}) and ground (V_{SS} , V_{SSA}) pins must always be connected to the external power supply system within the permitted range.
2. The maximum value of V_{IN} must be respected. Refer to the table below for the maximum allowed injected current values.

Table 5-2 Current characteristics

Symbol	Description	Maximum	Unit
$I_{VDD/VDDA}$ ⁽¹⁾	Total current through V_{DD}/V_{DDA} power pins (supply current) ⁽¹⁾	+120	mA
$I_{VSS/VSSA}$ ⁽¹⁾	Total current through V_{SS}/V_{SSA} ground pins (outflow current) ⁽¹⁾	-120	
I_{IO}	Output sink current on any I/O and control pins	+25	
	Output current on any I/O and control pins	-25	
$I_{INJ(PIN)}$ ⁽²⁾⁽³⁾	NRST pin injection current	± 5	
	HSE OSC_IN pin injection current	± 5	
$\sum I_{INJ(PIN)}$ ⁽⁵⁾	Other pins injection current ⁽⁴⁾	± 25	

1. All main power (V_{DD} , V_{DDA}) and ground (V_{SS} , V_{SSA}) pins must always be connected to an external power supply in the permitted range.
2. This current consumption must be correctly distributed to all I/O and control pins. The total output current must not be sunk/sourced between two consecutive power supply pins referring to high pin count LQFP package.
3. The reverse injection current can interfere with the analog performance of the device.
4. When $V_{IN} > V_{DDA}$, a positive injected current is generated; when $V_{IN} < V_{SS}$, a reverse injected current is generated. Do not exceed $I_{INJ(PIN)}$.
5. When there is simultaneous injection current for multiple inputs, the maximum value of $\sum I_{INJ(PIN)}$ is equal to the sum of the absolute values of the forward injection current and the reverse injection current (instantaneous value) .

5.3 Operating conditions

5.3.1 General operating conditions

Electrical characteristics

Table 5-3 General operating conditions

Symbol	Parameter	Conditions	Min.	Typ.	Max.	Unit
f _{HCLK}	Internal AHB clock frequency	-	-	-	72	MHz
f _{PCLK2}	Internal APB2 clock frequency	-	-	-	72	
f _{PCLK1}	Internal APB1 clock frequency	-	-	-	72	
V _{DD}	Digital circuit operating voltage	-	2.0	3.3	5.5	V
V _{DDA}	Analog circuit operating voltage (Performance is guaranteed)	Must be the same as V _{DD} ⁽¹⁾	2.5	3.3	5.5	
	Analog circuit operating voltage (Performance is not guaranteed)		2.0	-	2.5	
P _D	Power dissipation Temperature: T _A = 85°C ⁽²⁾ or: T _A = 105°C ⁽²⁾	LQFP48	-	-	357	mW
		LQFP32	-	-	333	
		QFN32	-	-	571	
		TSSOP20	-	-	270	
T _A	Ambient temperature (industrial level)	-	-40	-	85	°C
	Ambient temperature (extended industrial level)	-	-40	-	105	°C
T _J	Junction temperature ⁽³⁾ (industrial level)	-	-40	-	105	°C
	Junction temperature ⁽³⁾ (extended industrial level)	-	-40	-	125	°C

1. It is recommended to use the same power supply for V_{DD} and V_{DDA}, the maximum permissible difference between V_{DD} and V_{DDA} is 300mV during power up and normal operation.
2. If T_A is low, higher P_D values are allowed as long as T_J (T_J=125°C is the absolute maximum rating value) does not exceed T_{Jmax}.
3. In low power dissipation state, T_A can be extended to this range as long as T_J (T_J=125°C is the absolute maximum rating value) does not exceed T_{Jmax}.

5.3.2 Operating conditions at power-up/power-down

The parameters given in the table below are provided under the ambient temperature and the V_{DD} supply voltage listed in Table 5-3.

Table 5-4 Operating conditions at power-up/power-down

Symbol	Conditions	Min.	Typ.	Max.	Unit
t _{VDD}	V _{DD} rise time t _r	1	-	∞	us
	V _{DD} fall time t _f	400	-	∞	
V _{ft} ⁽³⁾	Power-down threshold voltage	-	0	-	mV

1. Data based on characterization results, not tested in production.
2. The V_{DD} waveforms of chip power-on and power-down must strictly follow the t_r and t_f phased in the following waveform diagram, and no power-down is allowed during power-on process.
3. Note: To ensure the reliability of chip power-on, all power-on should start from 0V.

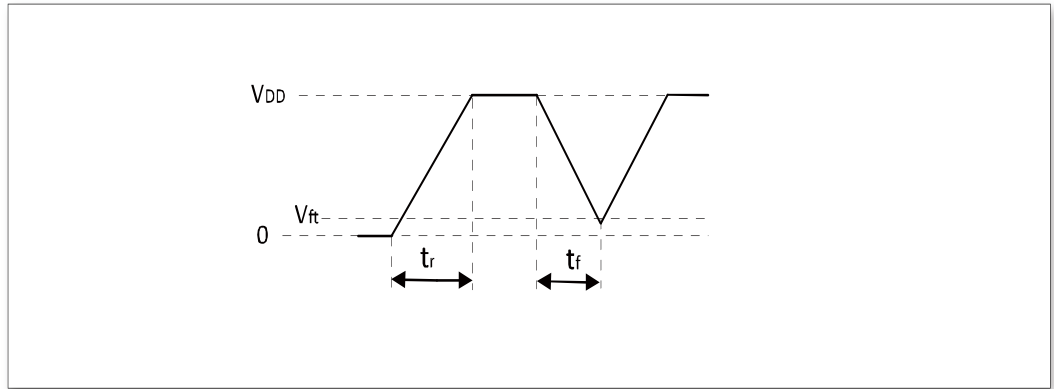

Figure 5-5 Power-on and power-down waveforms

5.3.3 Embedded reset and power control block characteristics

The parameters given in the table below are provided under the ambient temperature and the V_{DD} supply voltage listed in Table 5-3.

Table 5-5 Embedded reset and power control block characteristics

Symbol	Parameter	Condition	Min. ⁽³⁾	Typ.	Max. ⁽³⁾	Unit
V_{PVD}	Level selection of programmable voltage detectors	PLS[3:0]=0000 (Rising edge)	1.62	1.8	1.98	V
		PLS[3:0]=0000 (Falling edge)	1.53	1.7	1.87	
		PLS[3:0]=0001 (Rising edge)	1.89	2.1	2.31	
		PLS[3:0]=0001 (Falling edge)	1.80	2.0	2.20	
		PLS[3:0]=0010 (Rising edge)	2.16	2.4	2.64	
		PLS[3:0]=0010 (Falling edge)	2.07	2.3	2.53	
		PLS[3:0]=0011 (Rising edge)	2.43	2.7	2.97	
		PLS[3:0]=0011 (Falling edge)	2.34	2.6	2.86	
		PLS[3:0]=0100 (Rising edge)	2.70	3.0	3.30	
		PLS[3:0]=0100 (Falling edge)	2.61	2.9	3.19	
		PLS[3:0]=0101 (Rising edge)	2.97	3.3	3.63	
		PLS[3:0]=0101 (Falling edge)	2.88	3.2	3.52	
		PLS[3:0]=0110 (Rising edge)	3.24	3.6	3.96	
		PLS[3:0]=0110 (Falling edge)	3.15	3.5	3.85	
		PLS[3:0]=0111 (Rising edge)	3.51	3.9	4.29	
		PLS[3:0]=0111 (Falling edge)	3.42	3.8	4.18	
		PLS[3:0]=1000 (Rising edge)	3.78	4.2	4.62	
		PLS[3:0]=1000 (Falling edge)	3.69	4.1	4.51	

Symbol	Parameter	Condition	Min. ⁽³⁾	Typ.	Max. ⁽³⁾	Unit
		PLS[3:0]=1001 (Rising edge)	4.05	4.5	4.95	
		PLS[3:0]=1001 (Falling edge)	3.96	4.4	4.84	
		PLS[3:0]=1010 (Rising edge)	4.32	4.8	5.28	
		PLS[3:0]=1010 (Falling edge)	4.23	4.7	5.17	
V _{POR/PDR} ⁽¹⁾	Power-on reset threshold	-	-	1.65	-	V
V _{hyst_PDR}	PDR hysteresis	-	-	30	-	mV
T _{RSTTEMPO} ⁽²⁾	Reset duration	-	-	3	-	ms

1. The product behavior is guaranteed by design down to the minimum value V_{POR/PDR}.
2. Guaranteed by design, not tested in production.
3. Drawn from comprehensive evaluation.

Note: The reset duration is measured from power-on (POR reset) to the time when the user application code reads the first instruction

5.3.4 Built-in voltage reference

The parameters given in the table below are provided under the ambient temperature and the V_{DD} supply voltage listed in Table 5-3.

Table 5-6 Build-in voltage reference

Symbol	Parameter	Conditions	Min.	Typ.	Max.	Unit
V _{REFINT}	Built-in voltage reference	-40°C < T _A < 105°C	-	1.2	-	V
T _{s_vrefint} ⁽¹⁾	ADC sampling time when readout build-in voltage reference	-	-	11.8	-	us

1. The sampling time is obtained through multiple tests

5.3.5 Supply current characteristics

The current consumption is a function of several parameters and factors such as the operating voltage, temperature, I/O pin loading, device software configuration, operating frequencies, I/O pin switching rate, program location in memory and executed binary code. All Run-mode current consumption measurements given in this section are performed with a reduced code.

Maximum current consumption

The MCU is placed under the following conditions:

- All I/O pins are in analog input mode, and connected to a static level - V_{DD} or V_{SS} (no load)
- All peripherals are disabled except when explicitly mentioned

Electrical characteristics

- The Flash memory access time is adjusted to the f_{HCLK} (0 ~ 24 MHz is 0 waiting cycle, 24 ~ 48 MHz is 1 waiting cycle, 48 ~ 72 MHz is 2 waiting cycles).
- The instruction prefetching function is on. When the peripherals are enabled: $f_{PCLK1} = f_{HCLK}$.

Note: The instruction prefetching function must be set before setting the clock and bus divider.

The parameters given in the table below are based on the ambient temperature and the V_{DD} supply voltage listed in Table 5-3.

Table 5-7 Typical current consumption in Run mode

Symbol	Parameters	Condition	f_{HCLK} (Hz)	Typical All peripherals enabled				Typical All peripherals disabled				Unit
				-40°C	25°C	85°C	105°C	-40°C	25°C	85°C	105°C	
I_{DD}	Supply current in Run mode	Internal clock source	72M	16.26	16.22	16.30	16.19	10.15	10.12	10.20	10.10	mA
			48M	12.38	12.35	12.32	12.30	8.31	8.27	8.25	8.24	
			24M	7.81	7.74	7.72	7.71	5.78	5.70	5.68	5.68	
			8M	2.64	2.62	2.64	2.67	1.96	1.94	1.96	2.00	
			4M	1.99	1.98	2.01	2.03	1.61	1.60	1.63	1.63	
			2M	1.21	1.19	1.21	1.25	1.02	1.00	1.02	1.06	
			1M	0.81	0.79	0.81	0.84	0.72	0.69	0.71	0.75	
			500K	0.62	0.59	0.61	0.64	0.57	0.54	0.56	0.59	
			125K	0.47	0.44	0.46	0.49	0.46	0.43	0.45	0.48	

Table 5-8 Typical current consumption in Sleep mode

Symbol	Parameters	Condition	f_{HCLK} (Hz)	Typical All peripherals enabled				Typical All peripherals disabled				Unit
				-40°C	25°C	85°C	105°C	-40°C	25°C	85°C	105°C	
I_{DD}	Supply current in Sleep mode	Internal clock source	72M	10.25	10.13	10.02	9.92	4.13	4.04	3.99	3.94	mA
			48M	7.18	7.06	6.97	6.90	3.09	3.30	2.95	2.92	
			24M	4.10	4.00	3.94	3.90	2.06	1.97	1.93	1.91	
			4M	1.91	1.87	1.80	1.19	1.54	1.51	1.34	0.82	
			2M	1.16	1.11	1.15	1.18	0.97	0.93	0.96	1.00	
			1M	0.79	0.74	0.77	0.80	0.70	0.65	0.67	0.71	
			500K	0.60	0.56	0.58	0.61	0.56	0.51	0.53	0.56	
			125K	0.46	0.42	0.43	0.49	0.45	0.41	0.42	0.45	

Table 5-9 Typical and maximum current consumption in stop and Standby modes ⁽¹⁾

Symbol	Parameter	Conditions	Typical	Maximum ⁽²⁾		Unit
			25°C	25°C	-40~105°C	
I_{DD}	Supply current in Stop mode	Enter Stop mode after reset, $V_{DD}=3.3V$	70.22	150	324	μA

Electrical characteristics

Symbol	Parameter	Conditions	Typical	Maximum ⁽²⁾		Unit
			25°C	25°C	-40~105°C	
	Supply current in Deep Stop mode	Enter Deep Stop mode after reset, V _{DD} =3.3V	1.67	5	55	
	Supply current in Standby mode	IWDG disabled	0.41	3	5.62	

1. The I/O state is an analog input.
2. Drawn from comprehensive evaluation.

On-chip peripheral current consumption

The current consumption of the on-chip peripherals is given in the following table. The MCU is placed under the following conditions:

- All I/O pins are in analog input mode, and connected to a static level - V_{DD} or V_{SS} (no load) .
- All peripherals are disabled unless otherwise specified.
- The given value is calculated by measuring the current consumption.
 - When all peripherals are clocked off
 - When only one peripheral is clocked on
- Ambient operating temperature and V_{DD} supply voltage conditions are listed in Table 5-3.

Table 5-10 On-chip peripheral current consumption ⁽¹⁾

Symbol	Parameter	Bus	Typical	Unit
I _{DD}	CRC	AHB	0.95	uA/MHz
	GPIOA		0.55	
	GPIOB		0.56	
	GPIOC		0.52	
	GPIOD		0.54	
	DMA		2.1	
	HWDIV		1.2	
	TIM1	APB2	8.2	
	TIM14		2.0	
	TIM16		2.7	
	TIM17		2.8	
	SPI1		5.7	
	UART1		4.8	
	SYSCFG		0.2	
	MCUDBG		0.2	
	COMP		0.4	

Electrical characteristics

Symbol	Parameter	Bus	Typical	Unit
	EXTI	APB1	0.1	
	ADC		4.1	
	TIM2		5.8	
	TIM3		4.4	
	UART2		5.0	
	UART3		5.0	
	SPI2		5.7	
	IWDG		0.6	
	I2C1		6.8	
	WWDG		0.2	
	FlexCAN		11.1	

1. $f_{HCLK} = 72\text{MHz}$, $f_{APB1} = f_{HCLK}$, $f_{APB2} = f_{HCLK}$, the prescale coefficient of each peripheral is the default value.

Wake up time from low power mode

The wake-up time listed in the table below is measured during the wake-up process of the internal clock HSI. The clock source used to wake up the chip depends on the current operating mode:

Stop or Standby mode: the clock source is the oscillator

Sleep mode: the clock source is the clock used when entering the Sleep mode.

The parameters given in the table below are based on the ambient temperature and the V_{DD} supply voltage listed in Table 5-3.

Table 5-11 Wake up time from low power mode

Symbol	Parameter	Conditions	Typical	Unit
$t_{WUSLEEP}$	Wake up from Sleep mode	System clock is HSI	3	cycles
t_{WUSTOP}	Wake up from Stop mode (regulator is in Run mode)	System clock is HSI	11	μs
$t_{WUDEEPSTOP}$	Wake up from Deep Stop mode (regulator is in low power mode)	System clock is HSI	14	μs
$t_{WUSTDBY}$	Wake up from Standby mode	$PWR \rightarrow CR[15:14] = 0x1$	484	μs
$t_{WUSTDBY}$	Wake up from Standby mode	$PWR \rightarrow CR[15:14] = 0x2$	425	μs
$t_{WUSTDBY}$	Wake up from Standby mode	$PWR \rightarrow CR[15:14] = 0x3$	363	μs

5.3.6 External clock source characteristics

High-speed external user clock generated from an external source

The characteristic parameters given in the following table are measured by a high-speed

Electrical characteristics

external clock source, and the ambient temperature and power supply voltage meet General operating conditions.

Table 5-12 High-speed external user clock characteristics

Symbol	Parameter	Condition	Min.	Typ.	Max.	Unit
f_{HSE_ext}	User external clock source frequency ⁽¹⁾	-	-	8	32	MHz
V_{HSEH}	OSC_IN input high level voltage	-	$0.7V_{DD}$	-	V_{DD}	V
V_{HSEL}	OSC_IN input low level voltage	-	V_{SS}	-	$0.3V_{DD}$	V
$t_{w(HSE)}$	OSC_IN high or low time ⁽¹⁾	-	15	-	-	ns

1. Guaranteed by design, not tested in production

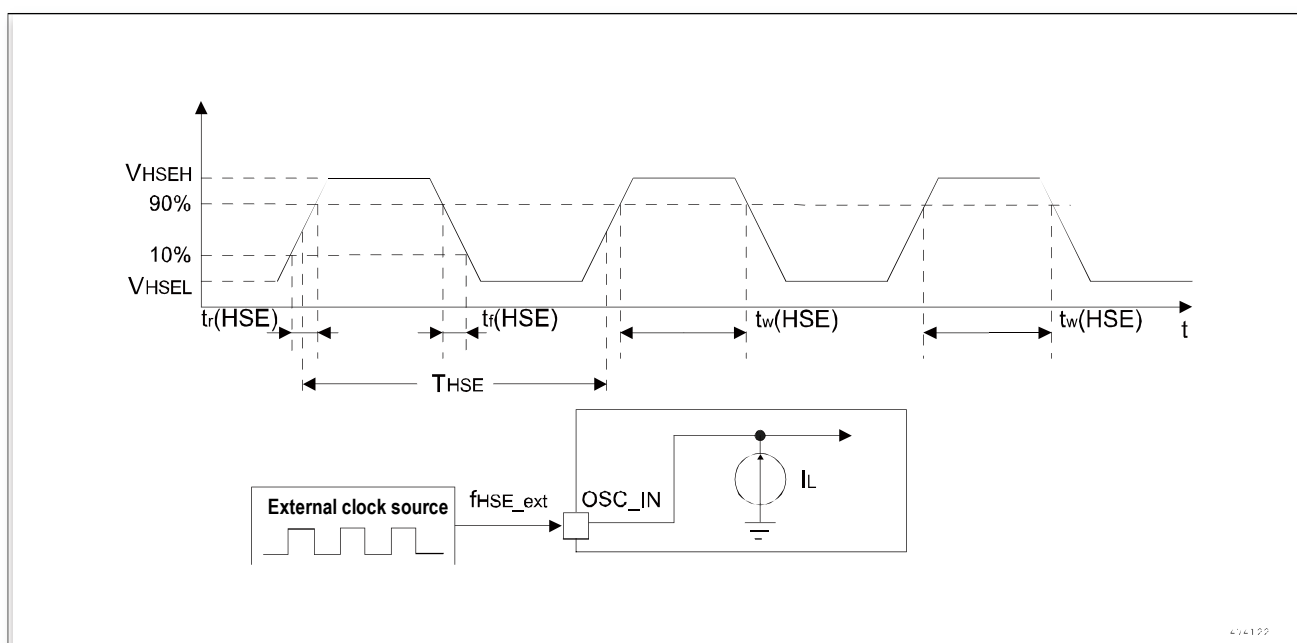

Figure 5-6 High-speed external clock source AC timing diagram

High-speed external clock generated from a crystal/ceramic resonator

The high-speed external (HSE) clock can be supplied with a 4 to 24 MHz crystal/ceramic resonator oscillator. All the information given in this paragraph is based on the design simulation results obtained with typical external components specified in the table below. In the application, the resonator and the load capacitors must be placed as close as possible to the oscillator pins to minimize output distortion and stabilization time at startup. Refer to the crystal resonator manufacturer for more details on the resonator characteristics (frequency, package, accuracy...).

Electrical characteristics

Table 5-13 HSE oscillator characteristics ⁽¹⁾⁽²⁾

Symbol	Parameter	Conditions	Min.	Typ.	Max.	Unit
f _{OSC_IN}	Oscillator frequency ⁽²⁾	2V<VDD<3.6V	4	8	12	MHz
		3.0V<VDD<5.5V	8	16	24	MHz
R _F	Feedback resistor ⁽⁴⁾	-	-	1000	-	kΩ
ESR	Support crystal serial impedance (C _{L1} C _{L2} ⁽³⁾ is 16pF)	f _{OSC_IN} =24MHz, V _{DD} =3V	-	-	50	Ω
		f _{OSC_IN} =12MHz, V _{DD} =2V	-	-	120	Ω
I ₂	HSE current consumption	f _{OSC_IN} =24MHz, ESR=30 V _{DD} = 3.3V, C _{L1} C _{L2} ⁽³⁾ is 20pF	-	1.5	-	mA
g _m	Oscillator transconductance	Start up	-	9	-	mA/V
t _{SU(HSE)} ⁽⁵⁾	Startup time	V _{DD} is stable	-	3	-	ms

1. Resonator characteristics given by the crystal/ceramic resonator manufacturer characteristics Parameter.
2. Guaranteed by design, not tested in production.
3. For C_{L1} and C_{L2}, it is recommended to use high-quality external ceramic capacitors in the 5 pF to 25 pF range (Typ.), designed for high-frequency applications, and selected to match the requirements of the crystal or resonator. C_{L1} and C_{L2} are usually the same size. The crystal manufacturer typically specifies a load capacitance which is the series combination of C_{L1} and C_{L2}. PCB and MCU pin capacitance must be included (10 pF can be used as a rough estimate of the combined pin and board capacitance) when sizing C_{L1} and C_{L2}.
4. The relatively low value of the R_F resistance can be used to avoid problems arising from the use of wet conditions to provide protection, this environment results in leakage and bias conditions have changed. However, if the MCU is applied in bad wet conditions, the design needs to take this parameter into account.
5. t_{SU(HSE)} is the startup time measured from the moment it is enabled (by software) to a stabilized 8 MHz oscillation is reached. This value is measured for a standard crystal resonator, and it can vary significantly with the crystal manufacturer.

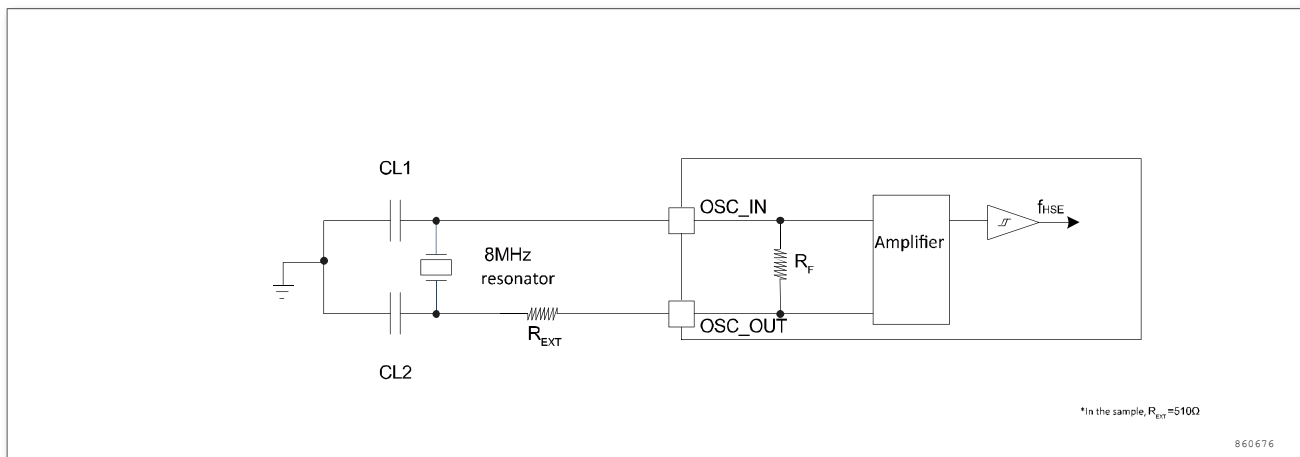

Figure 5-7 Typical application with an 8 MHz crystal

5.3.7 Internal clock source characteristics

The characteristic parameters given in the table below are measured using ambient temperature and supply voltage in accordance with general operating conditions.

High-speed internal (HSI) oscillator

Table 5-14 HSI oscillator characteristics ⁽¹⁾⁽²⁾

Symbol	Parameter	Conditions	Min.	Typ.	Max.	Unit
f _{HSI}	Frequency	-	-	8	-	MHz
ACC _{HSI}	HSI oscillator deviation	T _A = -40°C ~ 105°C	-2.5	-	+2.5	%
		T _A = -20°C ~ 85°C	-2	-	+2	%
		T _A = 25°C	-1	-	+1	%
T _{stab(HSI)}	HSI oscillator startup time	-	-	-	20	μs
I _{DD(HSI)}	HSI oscillator power consumption	-	-	80	-	μA

1. V_{DD} = 3.3V, T_A = - 40°C ~ 105°C, unless otherwise specified.
2. Guaranteed by design, not tested in production.

Low-speed internal (LSI) oscillator

Table 5-15 LSI oscillator characteristics ⁽¹⁾

Symbol	Parameter	Conditions	Min.	Typ.	Max.	Unit
f _{LSI} ⁽²⁾	Frequency	T _A = -40°C ~ 105°C	20	40	70	KHz
t _{SU(LSI)} ⁽³⁾	LSI oscillator startup time	-	-	-	100	μs
I _{DD(LSI)} ⁽³⁾	LSI oscillator power consumption	-	-	0.26	-	μA

1. V_{DD} = 3.3V, T_A = -40°C ~ 105°C, unless otherwise stated.
2. Drawn from comprehensive evaluation, not tested in production.

Electrical characteristics

3. Guaranteed by design, not tested in production.

5.3.8 PLL characteristics

The relationship between the input clock frequency f_{PLL_IN} and output clock f_{PLL_OUT} frequency is:

$$\frac{f_{PLL_IN}}{PLL_DIV[2:0] + 1} = \frac{f_{PLL_OUT}}{PLL_MUL[6:0] + 1}$$

PLL_MUL[6:0] and PLL_DIV[2:0] are the frequency division ratio settings of the PLL frequency divider and output frequency divider.

The parameters listed in the following table are provided under ambient temperature and power supply voltage in accordance with general working conditions.

Table 5-16 PLL characteristics ⁽¹⁾

Symbol	Parameter	Conditions	Min.	Typ.	Max.	Unit
f_{PLL_IN}	PLL input clock ⁽²⁾	-	4	8	24	MHz
D_{PLL_IN}	PLL input clock duty cycle	-	20	-	80	%
f_{VCO}	VCO output clock	-	80	-	200	MHz
f_{PLL_OUT}	PLL output clock	-	40	-	100	MHz
$I_{DD(PLL)}$	PLL current consumption	-	-	1550	-	uA

1. Guaranteed by design, not tested in production.
2. Use the correct multiplication factor to ensure the f_{PLL_OUT} is within the allowable range according to the PLL input clock frequency.

5.3.9 Memory characteristics

Table 5-17 Flash memory characteristics

Symbol	Parameter	Conditions	Min.	Typ.	Max.	Unit
t_{prog}	16-bit programming time	-	131.5	-	154.5	μs
t_{ERASE}	Page (1024 bytes) erase time	-	4	-	6	ms
t_{ME}	Mass erase time	-	30	-	40	ms
I_{DD}	Supply current	Read mode 40MHz	-	-	2	mA
		Write mode	-	-	1.2	mA
		Erase mode	-	-	0.6	mA

Table 5-18 Flash memory endurance and data retention ⁽¹⁾⁽²⁾

Symbol	Parameter	Conditions	Min.	Typ.	Max.	Unit
N_{END}	Endurance	-	100000	-	-	Cycles

Symbol	Parameter	Conditions	Min.	Typ.	Max.	Unit
T _{DR}	Data retention	T _A = 105°C	10	-	-	Years
		T _A = 85°C	20	-	-	
		T _A = 25°C	100	-	-	

5.3.10 EMC characteristics

Susceptibility tests are performed on a sample basis during device characterization.

Functional EMS (electromagnetic susceptibility)

While a simple application is executed on the device (toggling 2 LEDs through I/O ports), the device is stressed by two electromagnetic events until a failure occurs. The failure is indicated by the LEDs:

- Electrostatic discharge (ESD) (positive and negative) is applied to all device pins until a functional disturbance occurs. This test is compliant with the IEC 61000-4-2 standard.
- FTB: A Burst of Fast Transient voltage (positive and negative) is applied to VDD and VSS through a 100 pF capacitor, until a functional disturbance occurs. This test is compliant with the IEC 1000-4-4 standard.

A device reset allows normal operations to be resumed. The test results are given in the following table.

Table 5-19 EMS characteristics

Symbol	Parameter	Conditions	Level/Type
V _{FESD}	Voltage limit applied to any I/O pin, resulting in malfunction	V _{DD} = 3.3V, T _A = +25°C, f _{HCLK} = 72MHz. Conforming to IEC61000-4-2	2A
V _{FEEFT}	Fast transient voltage burst limits to be applied through 100 pF on VDD and VSS pins to induce a functional disturbance	V _{DD} = 3.3V, T _A = +25°C, f _{HCLK} = 72MHz. Conforming to IEC61000-4-4	2A

Designing hardened software to avoid noise problems

EMC characterization and optimization are performed at component level with a typical application environment and simplified MCU software. It should be noted that good EMC performance is highly dependent on the user application and the software.

Therefore, it is recommended that the user applies EMC software optimization and prequalification tests in relation with the EMC level requested for his application.

Software recommendations

The software flowchart must include the management of runaway conditions such as:

- Corrupted program counter

Electrical characteristics

- Unexpected reset
- Critical Data corruption (for example control registers)

Prequalification trials

Most of the common failures (unexpected reset and program counter corruption) can be reproduced by manually forcing a low state on the NRST pin or the Oscillator pins for 1 second.

To complete these trials, ESD stress can be applied directly on the device, over the range of specification values. When unexpected behavior is detected, the software can be hardened to prevent unrecoverable errors.

5.3.11 Functional EMS (Electrical Sensitivity)

Based on three different tests (ESD, LU) using specific measurement methods, the device is stressed to determine its performance in terms of electrical sensitivity.

Electrostatic discharge (ESD)

Electrostatic discharges (a positive then a negative pulse separated by 1 second) are applied to the pins of each sample according to each pin combination. The sample size depends on the number of supply pins in the device (3 parts × (n+1) supply pins). This test conforms to the JESD22-A114/C101 standard.

Static latch-up

Two complementary static latch-up tests are required on six parts to assess the latch-up performance:

- A supply overvoltage is applied to each power supply pin
- A current injection is applied to each input, output, and configurable I/O pin

These tests are compliant with EIA/JESD78E IC latch-up standard.

Table 5-20 ESD & LU characteristics

Symbol	Parameter	Conditions	Maximum	Unit
$V_{ESD(HBM)}$	Electrostatic discharge voltage (Human body model)	$T_A = 25^{\circ}\text{C}$, conforming to ESDA/JEDEC JS-001-2017	± 6000	V
$V_{ESD(CDM)}$	Electrostatic discharge voltage (Charging device model)	$T_A = 25^{\circ}\text{C}$, conforming to ESDA/JEDEC JS-002-2018	± 2000	V
I_{LU}	Latch-up current	$T_A = 105^{\circ}\text{C}$, conforming to JESD78E	± 300	mA

5.3.12 I/O port characteristics

General input/output characteristics

Unless otherwise specified, the parameters given in Table 5-3 are used for tests. All I/O ports are CMOS compatible.

Table 5-21 I/O static characteristics

Symbol	Parameter	Conditions	Minimum	Typical	Maximum	Unit
V _{IL}	Low level input voltage	V _{DD} = 3.3V	-	-	0.8	V
V _{IL}	Low level input voltage	V _{DD} = 5V	-	-	0.3 * V _{DD}	V
V _{IH}	High level input voltage	V _{DD} = 3.3V	2.0	-	-	V
V _{IH}	High level input voltage	V _{DD} = 5V	0.7 * V _{DD}	-	-	V
V _{hy}	Schmitt trigger hysteresis ⁽¹⁾	V _{DD} = 3.3V	0.1 * V _{DD}	0.50	-	V
V _{hy}	Schmitt trigger hysteresis ⁽¹⁾	V _{DD} = 5V	0.1 * V _{DD}	0.60	-	V
I _{lkg}	Input leakage current ⁽²⁾	V _{DD} = 3.3V	-1	-	1	μA
I _{lkg}	Input leakage current ⁽²⁾	V _{DD} = 5V	-1	-	1	μA
R _{PU}	Weak pull-up equivalent resistor ⁽³⁾	V _{DD} = 3.3V, V _{IN} = V _{SS}	50	60	75	kΩ
R _{PU}	Weak pull-up equivalent resistor ⁽³⁾	V _{DD} = 5V, V _{IN} = V _{SS}	50	60	75	kΩ
R _{PD}	Weak pull-down equivalent resistor ⁽³⁾	V _{DD} = 3.3V, V _{IN} = V _{DD}	50	60	75	kΩ
R _{PD}	Weak pull-down equivalent resistor ⁽³⁾	V _{DD} = 5V, V _{IN} = V _{DD}	50	60	75	kΩ
C _{IO}	I/O pin capacitance	-	-	-	10	pF

1. Drawn from comprehensive evaluation, not tested in production.
2. If there is reverse current in the adjacent pin, the leakage current may be higher than the maximum value.
3. The pull-up and pull-down resistors are poly resistors.

Output driving current

The GPIOs (general purpose input/outputs) can sink or source up to ±20mA.

In the user application, the number of I/O pins must ensure that the drive current must be limited to respect the absolute maximum rating specified in Table 5-1:

- The sum of the currents sourced by all the I/O pins on V_{DD}, plus the maximum operating current that the MCU sourced on V_{DD}, cannot exceed the absolute maximum rating I_{VDD}.
- The sum of the currents drawn by all I/O ports and flowing out of V_{SS}, plus the maximum operating current of the MCU flowing out on V_{SS}, cannot exceed the absolute maximum rating I_{VSS}.

Output voltage levels

Unless otherwise stated, the parameters listed in the table below are provided under the

Electrical characteristics

ambient temperature and VDD supply voltage in accordance with the conditions summarized in Table 5-3. All I/O ports are CMOS compatible.

Table 5-22 Output voltage static characteristics

MODE[1:0]	Symbol	Parameter	Conditions	Minimum	Typical	Maximum	Unit
11	$V_{OL}^{(1)}$	Output low voltage	$ I_{IO} = 6\text{mA}$, $V_{DD} = 3.3\text{V}$	-	0.16	-	V
	$V_{OH}^{(2)}$	Output high voltage		-	3.11	-	
	$V_{OL}^{(1)(3)}$	Output low voltage	$ I_{IO} = 8\text{mA}$, $V_{DD} = 3.3\text{V}$	-	0.2	0.4	
	$V_{OH}^{(2)(3)}$	Output high voltage		2.4	3.05	-	
	$V_{OL}^{(2)(3)}$	Output low voltage	$ I_{IO} = 20\text{mA}$, $V_{DD} = 3.3\text{V}$	-	0.57	-	
	$V_{OH}^{(2)(3)}$	Output high voltage		-	2.62	-	
10	$V_{OL}^{(1)}$	Output low voltage	$ I_{IO} = 6\text{mA}$, $V_{DD} = 3.3\text{V}$	-	0.31	-	
	$V_{OH}^{(2)}$	Output high voltage		-	2.93	-	
	$V_{OL}^{(1)(3)}$	Output low voltage	$ I_{IO} = 8\text{mA}$, $V_{DD} = 3.3\text{V}$	-	0.42	-	
	$V_{OH}^{(2)(3)}$	Output high voltage		-	2.79	-	
01	$V_{OL}^{(1)}$	Output low voltage	$ I_{IO} = 6\text{mA}$, $V_{DD} = 3.3\text{V}$	-	0.31	-	
	$V_{OH}^{(2)}$	Output high voltage		-	2.93	-	
	$V_{OL}^{(1)(3)}$	Output low voltage	$ I_{IO} = 8\text{mA}$, $V_{DD} = 3.3\text{V}$	-	0.42	-	
	$V_{OH}^{(2)(3)}$	Output high voltage		-	2.79	-	

1. The current I_{IO} drawn by the chip must always follow the absolute maximum ratings given in the table, and the sum of I_{IO} (all I/O pins and control pins) cannot exceed I_{VSS} .
2. The current I_{IO} output by the chip must always follow the absolute maximum ratings given in the table, and the sum of I_{IO} (all I/O pins and control pins) cannot exceed I_{VDD} .
3. Resulted from comprehensive evaluation.

Input/output AC characteristics

The definitions and values of the input and output AC characteristics are given in the following figure and table, respectively.

Unless otherwise stated, the parameters listed in the following table are provided under the ambient temperature and supply voltage in accordance with the condition Table 5-3.

Table 5-23 I/O AC characteristics ⁽¹⁾⁽²⁾⁽³⁾

MODE[1:0]	Symbol	Parameter	Conditions	Minimum	Typical	Maximum	Unit
11	$t_{f(I/O)out}$	Output fall time	$C_L = 50\text{pF}$ $V_{DD} = 3.3\text{V}$	3.34	4.4	9.27	ns
	$t_{r(I/O)out}$	Output rise time		3.34	4.4	9.27	ns
10	$t_{f(I/O)out}$	Output fall time		5.91	10.9	17.0	ns
	$t_{r(I/O)out}$	Output rise time		5.91	10.6	17.0	ns
01	$t_{f(I/O)out}$	Output fall time		6.06	10.9	17.4	ns

Electrical characteristics

MODE[1:0]	Symbol	Parameter	Conditions	Minimum	Typical	Maximum	Unit
	$t_{r(I/O)out}$	Output rise time		6.06	10.8	17.4	ns

1. The speed of the I/O port can be configured through MODEx[1:0]. Refer to the description of the GPIO port configuration register in this chip user manual.
2. The maximum frequency is defined in Figure 5-8.
3. Guaranteed by design, not tested in production.

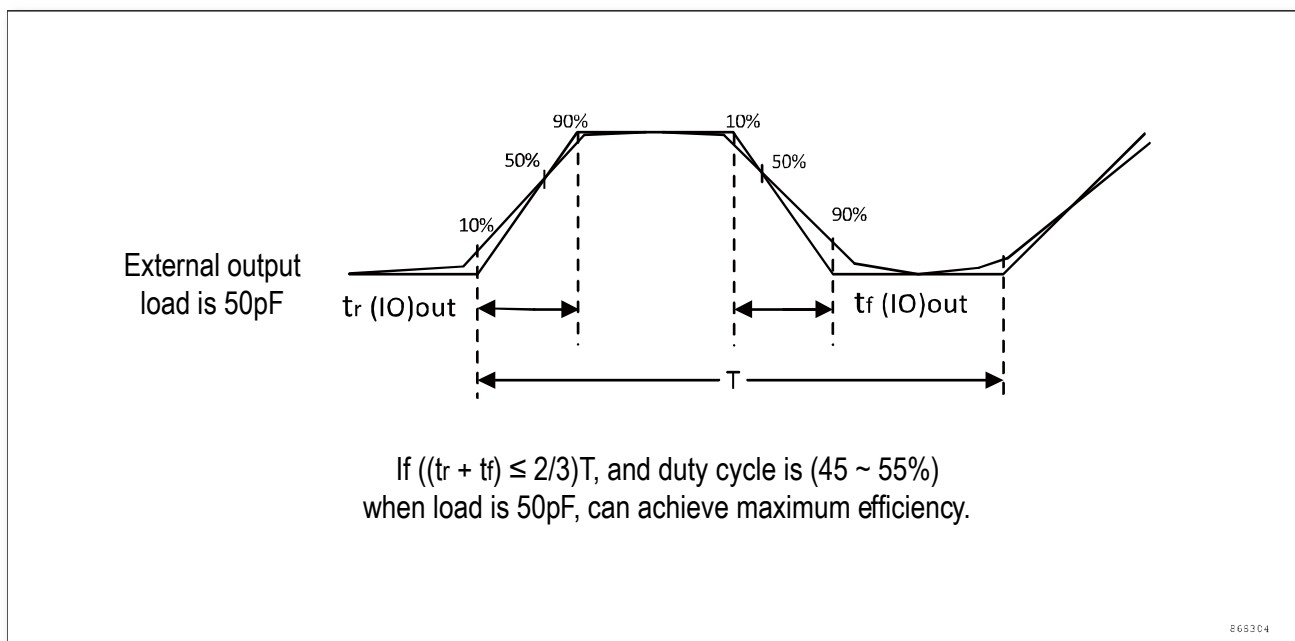

Figure 5-8 I/O AC characteristics

5.3.13 NRST pin characteristics

The NRST pin input driver uses the CMOS technology. It is connected to a permanent pullup resistor, R_{PU} .

Unless otherwise stated, the parameters listed in the table below are measured under the ambient temperature and V_{DD} supply voltage in accordance with the condition summarized in Table 5-3.

Table 5-24 NRST pin characteristics

Symbol	Parameter	Conditions	Min.	Typ.	Max.	Unit
$V_{IL(NRST)}^{(1)}$	NRST input low voltage	$V_{DD}=3.3V$	-	-	1.4	V
$V_{IH(NRST)}^{(1)}$	NRST input high voltage	$V_{DD}=3.3V$	2.0	-	-	V
$V_{hys(NRST)}$	NRST Schmitt trigger voltage hysteresis	$V_{DD}=3.3V$		0.6		V
R_{PU}	Weak pull-up equivalent resistor ⁽¹⁾	$V_{IN} = V_{SS}$	50	60	75	k Ω
$V_{F(NRST)}^{(1)}$	NRST input filtered pulse	-	-	-	1.0	μS
$V_{NF(NRST)}^{(1)}$	NRST input not filtered pulse	-	4.0	-	-	μS

Electrical characteristics

1. Guaranteed by design, not tested in production.

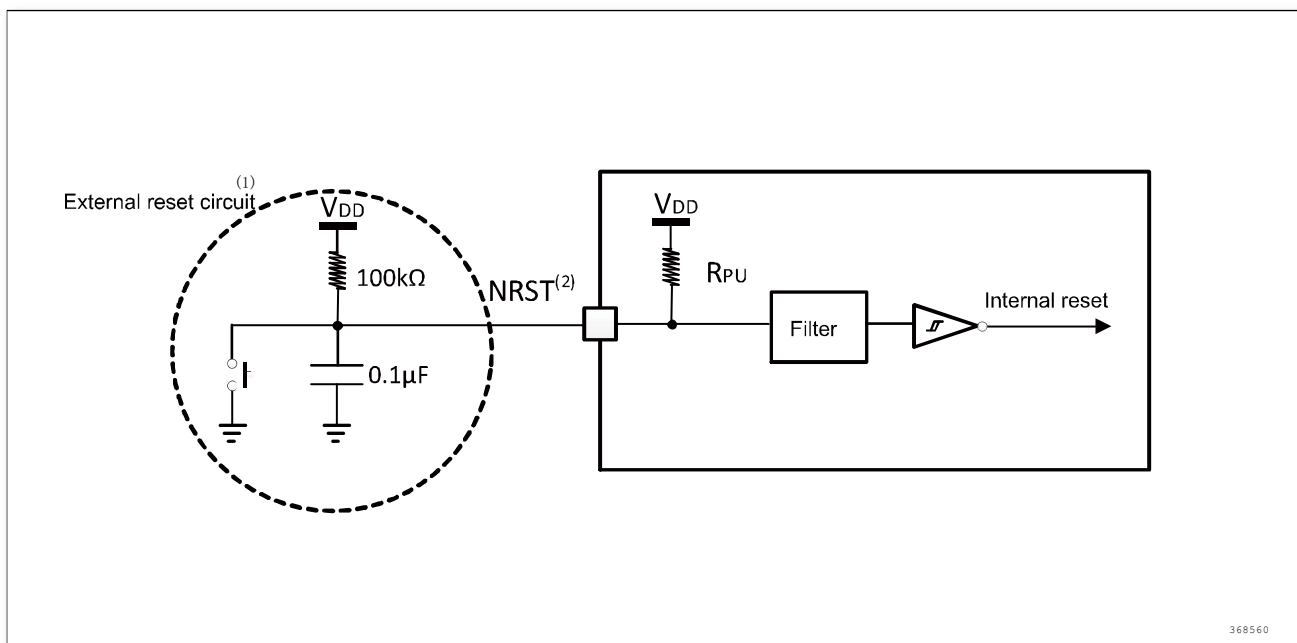

Figure 5-9 Recommended NRST pin protection

1. The reset network is to prevent parasitic reset
2. The user must ensure that the potential of the NRST pin is below the maximum $V_{IL(NRST)}$ listed in Table 5-24, otherwise the MCU cannot be reset.

5.3.14 Timer characteristics

The parameters listed in the following table are guaranteed by design.

For details on the characteristics of the input and output multiplex function pins (output compare, input capture, external clock, PWM output), see section 5.3.12 I/O port characteristics.

Table 5-25 TIMx ⁽¹⁾ characteristics

Symbol	Parameter	Condition	Minimum	Maximum	Unit
$t_{res(TIM)}$	Timer resolution	-	1	-	$t_{TIMxCLK}$
		$f_{TIMxCLK} = 72MHz$	13.89	-	ns
f_{EXT}	External clock frequency of channel 1 to 4	-	0	-	MHz
		$f_{TIMxCLK} = 72MHz$	0	72	
Res_{TIM}	Timer resolution	-	-	16	bit
$t_{COUNTER}$	16-bit counter period	-	1	65536	$t_{TIMxCLK}$
		$f_{TIMxCLK} = 72MHz$	0.01389	910.2	μs
t_{MAX_COUNT}		-	-	$65536 * 65536$	$t_{TIMxCLK}$

Electrical characteristics

Symbol	Parameter	Condition	Minimum	Maximum	Unit
	Maximum possible counter value (TIM_PSC adjustable)	$f_{TIMxCLK} = 72\text{MHz}$	-	59.7	S
t_{MAX_IN}	TIM maximum input frequency	-	-	144	MHz

1. Guaranteed by design, not tested in production.

5.3.15 Communication interfaces

I2C interface characteristics

Unless otherwise specified, the parameters given in the following table are derived from tests performed under the ambient temperature, f_{PCLK1} frequency and supply voltage conditions summarized in Table 5-3.

The I2C interface conforms to the standard I2C communication protocol but has the following limitations: SDA and SCL are not true open-drain pins. When configured as open-drain output, the PMOS transistor between the pin and V_{DD} is disabled, but still present.

The I2C characteristics are listed in the following table. Refer to section 5.3.12 I/O port characteristics for details on the characteristics of input/output alternate function pins (SDA and SCL).

Table 5-26 I2C characteristics

Symbol	Parameter	Standard I2C ⁽¹⁾		Fast mode I2C ⁽¹⁾		Unit
		Minimum	Maximum	Minimum	Maximum	
$t_w(SCLL)$	SCL clock low time	$8 \cdot t_{PCLK}$	-	$8 \cdot t_{PCLK}$	-	μs
$t_w(SCLH)$	SCL clock high time	$6 \cdot t_{PCLK}$	-	$6 \cdot t_{PCLK}$	-	μs
$t_{su}(SDA)$	SDA setup time	$2 \cdot t_{PCLK}$	-	$2 \cdot t_{PCLK}$	-	ns
$t_h(SDA)$	SDA data retention time	0 ⁽³⁾	- ⁽⁴⁾	0 ⁽³⁾	- ⁽⁴⁾	ns
$t_r(SDA)$ $t_r(SCL)$	SDA and SCL rising time	-	1000	-	300	ns
$t_f(SDA)$ $t_f(SCL)$	SDA and SCL fall time	-	300	-	300	ns
$t_{vd}(DAT)$ ⁽⁵⁾	Data valid time	-	$6 \cdot t_{PCLK} - 1$ ⁽⁴⁾	-	$6 \cdot t_{PCLK} - 0.3$ ⁽⁴⁾	μs
$t_{vd}(ACK)$ ⁽⁶⁾	Data valid acknowledge time	-	$6 \cdot t_{PCLK} - 1$ ⁽⁴⁾	-	$6 \cdot t_{PCLK} - 0.3$ ⁽⁴⁾	μs
$t_h(STA)$	Start condition hold time	$8 \cdot t_{PCLK}$	-	$8 \cdot t_{PCLK}$	-	μs
$t_{su}(STA)$	Start condition setup time	$6 \cdot t_{PCLK}$	-	$6 \cdot t_{PCLK}$	-	μs
$t_{su}(STO)$	Stop condition setup time	$6 \cdot t_{PCLK}$	-	$6 \cdot t_{PCLK}$	-	μs
$t_w(STO:STA)$	Time from Stop condition to Start condition (bus idle)	$5 \cdot t_{PCLK}$	-	$5 \cdot t_{PCLK}$	-	μs
C_b	Capacitive load of each bus	4.7	-	1.2	-	pF

1. Guaranteed by design, not tested in production.

Electrical characteristics

2. f_{PCLK1} must be at least 3MHz to achieve standard mode I2C frequencies. It must be at least 12MHz to achieve fast mode I2C frequencies.
3. Ensure SCL drops below $0.3V_{\text{DD}}$ on falling edge before SDA crosses into the indeterminate range of $0.3V_{\text{DD}}$ to $0.7V_{\text{DD}}$.

NOTE: For controllers that cannot observe the SCL falling edge then independent measurement of the time for the SCL transition from static high (V_{DD}) to $0.3V_{\text{DD}}$ should be used to insert a delay of the SDA transition with respect to SCL.

4. The maximum $t_{\text{h(SDA)}}$ could be 3.45 us and 0.9 us for Standard mode and Fast mode, but must be less than the maximum of $t_{\text{vd(DAT)}}$ or $t_{\text{vd(ACK)}}$ by a transition time. This maximum must only be met if the device does not stretch the LOW period ($t_{\text{w(SCL)}}$) of the SCL signal. If the clock stretches the SCL, the data must be valid by the setup time before it releases the clock.
5. $t_{\text{vd(DAT)}}$ = time for data signal from SCL LOW to SDA output.
6. $t_{\text{vd(ACK)}}$ = time for Acknowledgement signal from SCL LOW to SDA output.

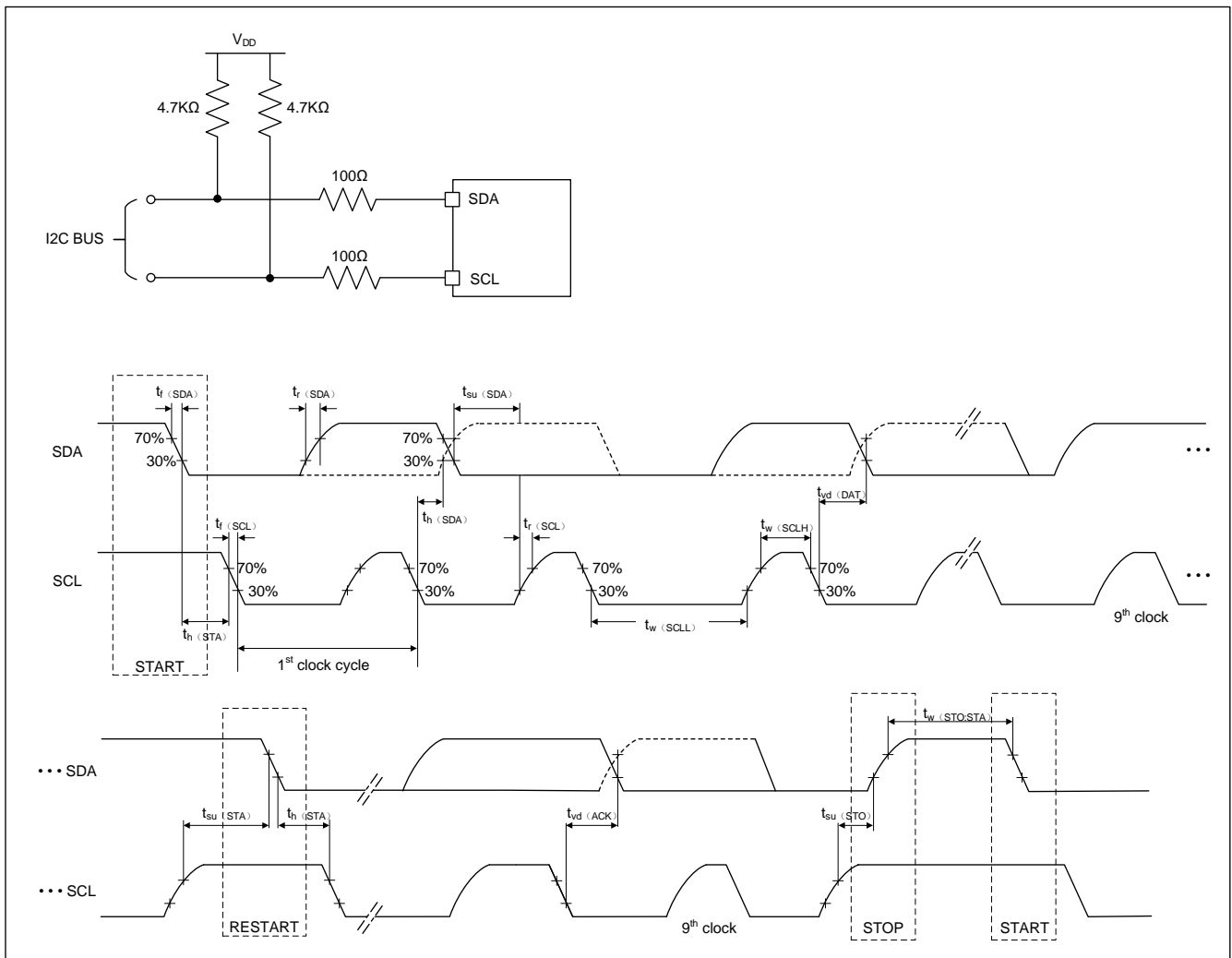

Figure 5-10 I2C bus AC waveform and measurement circuit (1)

1. Measurement point is set to the CMOS level: $0.3V_{\text{DD}}$ and $0.7V_{\text{DD}}$.

SPI characteristics

Unless otherwise specified, the parameters given in the following table are derived from tests performed under the ambient temperature, f_{PCLKx} frequency and V_{DD} supply voltage conditions summarized in Table 5-3.

Refer to section 5.3.12 I/O port characteristics for more details on the input/output alternate function characteristics (NSS, SCK, MOSI, MISO).

Table 5-27 SPI characteristics ⁽¹⁾

Symbol	Parameter	Conditions	Minimum	Maximum	Unit
f_{SCK} $1/t_{c(SCK)}$	SPI clock frequency	Master mode, $T_A = 25^\circ\text{C}$	-	36 ⁽⁴⁾	MHz
		Slave mode, $T_A = 25^\circ\text{C}$	-	18	
$t_r(SCK)$	SPI clock rise time	Load capacitance: $C = 15\text{pF}$	-	6	ns
$t_f(SCK)$	SPI clock fall time	Load capacitance: $C = 15\text{pF}$	-	6	ns
$t_{su(NSS)}^{(1)}$	NSS setup time	Slave mode	10	-	ns
$t_{h(NSS)}^{(1)}$	NSS hold time	Slave mode	10	-	ns
$t_{w(SCKH)}^{(1)}$	SCK high time	-	$t_{c(SCK)}/2 - 6$	$t_{c(SCK)}/2 + 6$	ns
$t_{w(SCKL)}^{(1)}$	SCK low time	-	$t_{c(SCK)}/2 - 6$	$t_{c(SCK)}/2 + 6$	ns
$t_{su(MI)}^{(1)}$	Data input setup time	Master mode, $f_{PCLK} = 48\text{MHz}$, prescaler = 2, high speed mode	15	-	ns
$t_{su(SI)}^{(1)}$		Slave mode	5	-	ns
$t_{h(MI)}^{(1)}$	Data input hold time	Master mode, $f_{PCLK} = 48\text{MHz}$, prescaler = 2, high speed mode	0	-	ns
$t_{h(SI)}^{(1)}$		Slave mode	5	-	ns
$t_{v(MO)}^{(1)}$	Data output valid time	Master mode (after enable edge)	-	15	ns
$t_{v(SO)}^{(1)}$	Data output valid time	Slave mode (after enable edge)	-	15	ns

1. Data based on characterization results. Not tested in production.
2. Min time is for the minimum time to drive the output and the max time is for the maximum time to validate the data.
3. Min time is for the minimum time to invalidate the output and the max time is for the maximum time to put the data in Hi-Z.
4. When the SPI works at its limit speed, it is recommended to connect a serial matching resistor to the SCK wire to ensure the stability of transmission; and ensure that the SCK wire of the SPI Master and SPI Slave are as short as possible.

Electrical characteristics

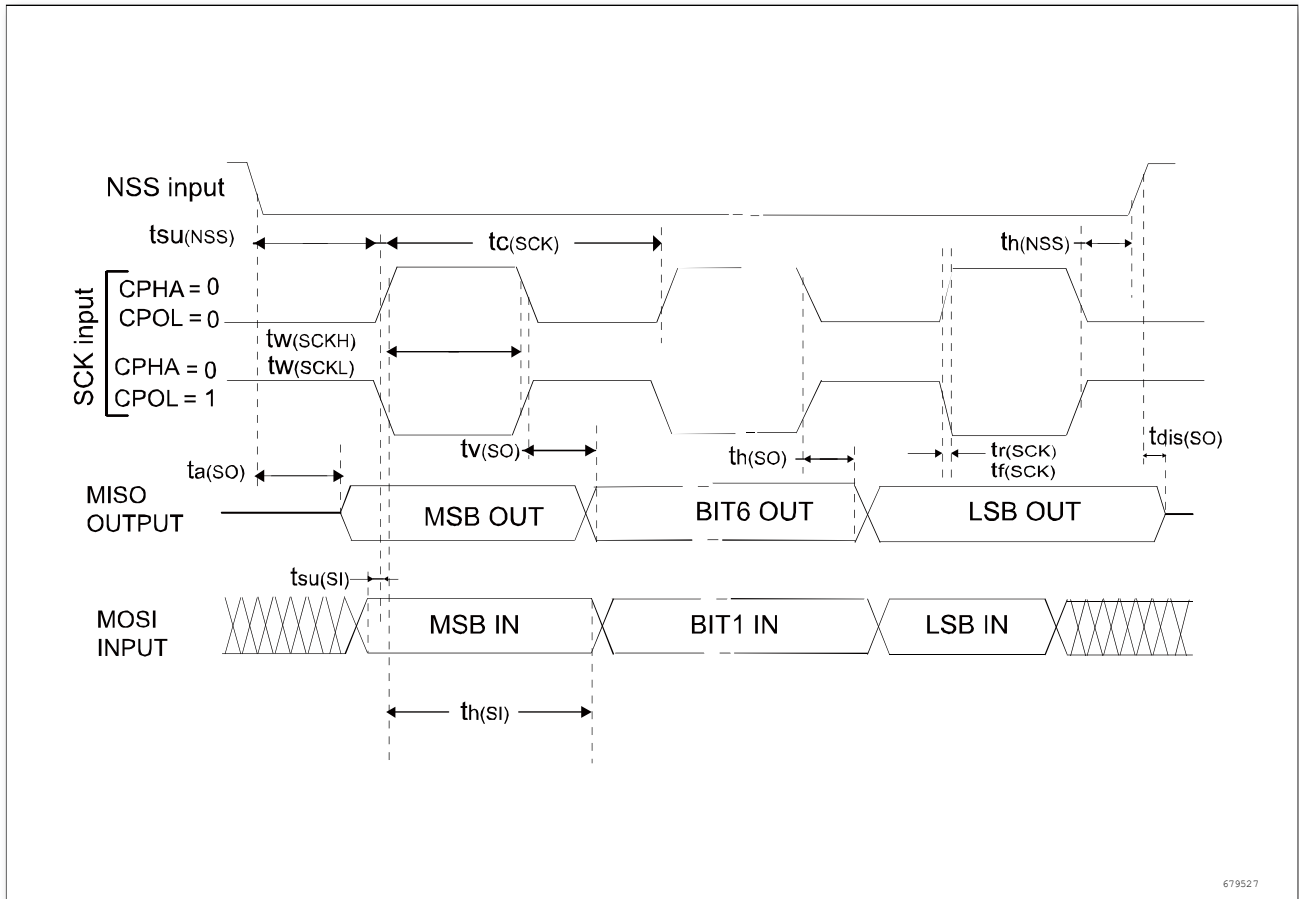

Figure 5-11 SPI timing diagram-slave mode and CPHA = 0, CPHASEL = 1

Electrical characteristics

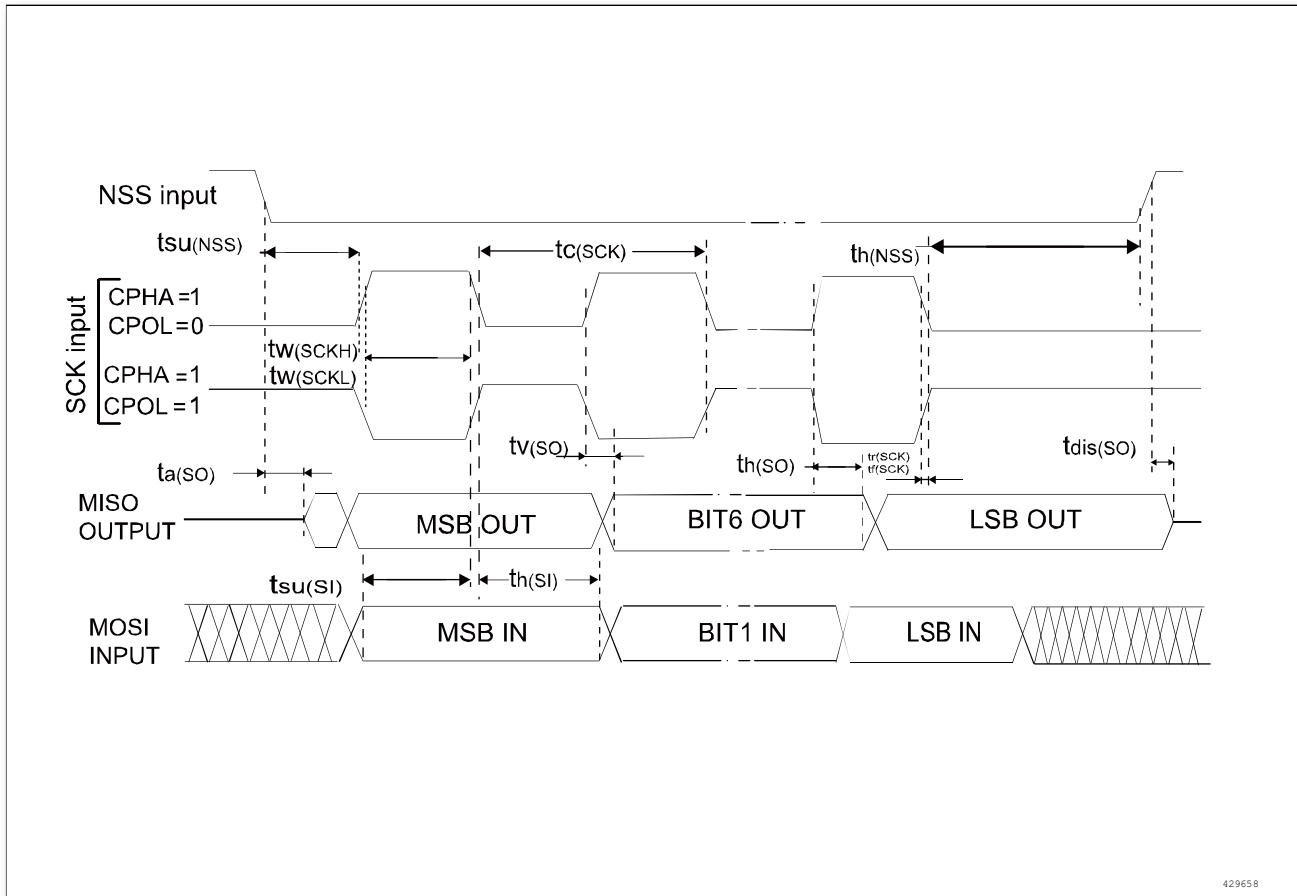

Figure 5-12 SPI timing diagram-slave mode and CPHA = 1, CPHASEL = 1 ⁽¹⁾

1. Measurement points are set at CMOS levels: $0.3V_{DD}$ and $0.7V_{DD}$

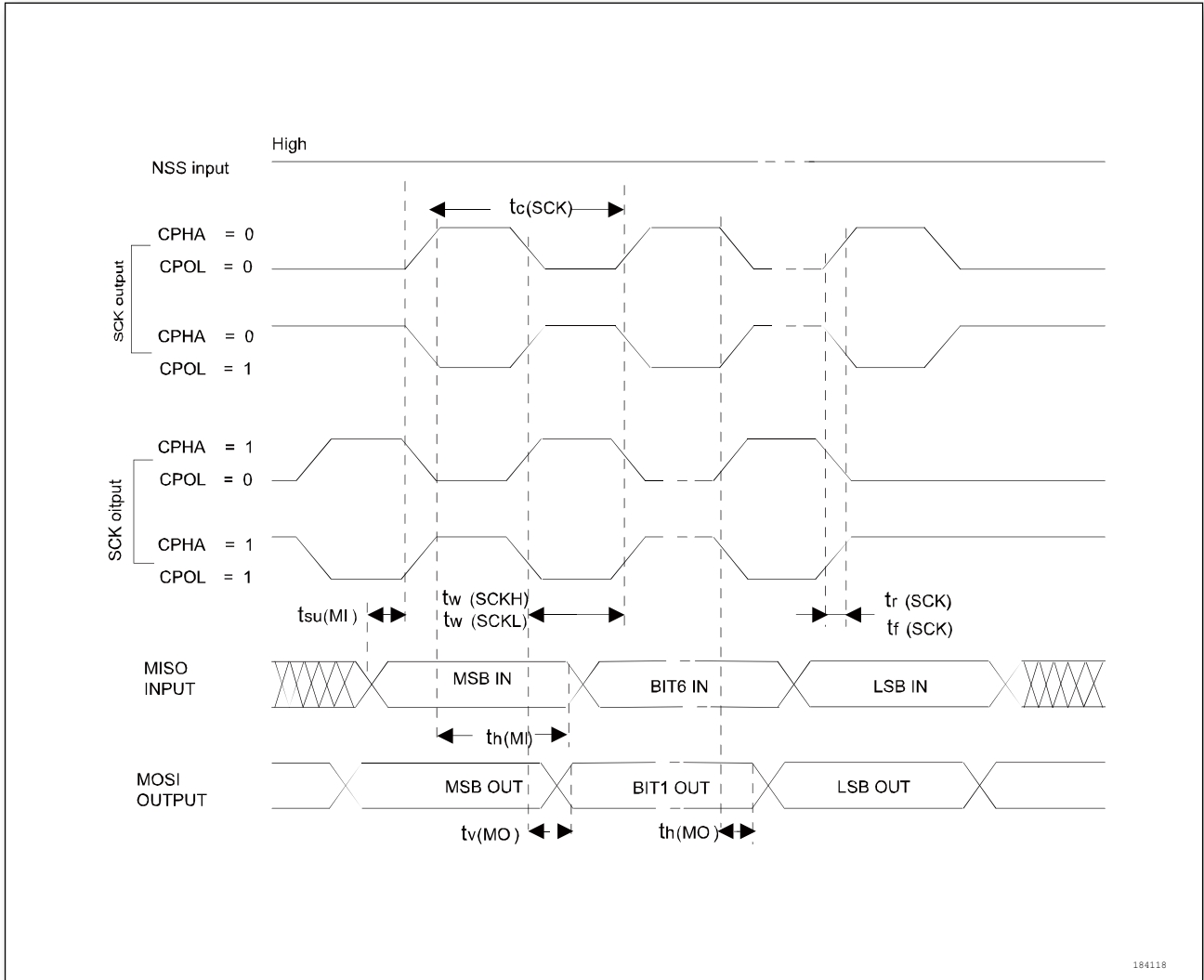

Figure 5-13 SPI timing diagram-master mode, CPHASEL = 1 ⁽¹⁾

1. Measurement points are set at CMOS levels: 0.3V_{DD} and 0.7V_{DD}.

5.3.16 FlexCAN interface

For details on the characteristics of the input and output alternate function pins (CAN_TX and CAN_RX), see section 5.3.12 I/O port characteristics.

5.3.17 ADC characteristics

Unless otherwise specified, the parameters in the table below are measured under the ambient temperature, f_{PCLK2} frequency and V_{DDA} supply voltage in accordance with the conditions summarized in Table 5-3.

Electrical characteristics

Table 5-28 ADC characteristics

Symbol	Parameter	Conditions	Min.	Typ.	Max.	Unit
V _{DDA}	Supply voltage	-	2.5	3.3	5.5	V
f _{ADC}	ADC clock frequency	-	-	-	16	MHz
f _s ⁽¹⁾	Sampling frequency	-	-	-	1	MHz
f _{TRIG} ⁽¹⁾	External trigger frequency ⁽³⁾	f _{ADC} = 16MHz	-	-	1	MHz
		-	-	-	16	1/f _{ADC}
V _{AIN} ⁽²⁾	Conversion voltage range	-	0	-	V _{DDA}	V
R _{AIN} ⁽¹⁾	External input impedance	-	See equation 2			kΩ
R _{ADC} ⁽¹⁾	Sampling switch resistance	-	-	-	1.5	kΩ
C _{ADC} ⁽¹⁾	Internal sample and hold capacitance	-	-	-	10	pF
t _{STAB} ⁽¹⁾	Stabilization time	-	-	-	10	μs
t _{latr} ⁽¹⁾	Delay between trigger and conversion start	-	-	-	-	1/f _{ADC}
t _s ⁽¹⁾	Sampling time	f _{ADC} = 16MHz	0.156	-	15.031	μs
		-	2.5	-	240.5	1/f _{ADC}
t _{CONV} ⁽¹⁾	Total conversion time (including sampling time)	f _{ADC} = 16MHz	0.9375	-	15.8125	μs
		-	15 ~ 253 (sampling t _s + successive approximation 12.5)			1/f _{ADC}
ENOB	Effective number of bits	-	-	10.7	-	bit

1. Guaranteed based on test during characterization. Not tested in production.
2. Guaranteed by design, not tested in production.
3. In this product, VREF+ is internally connected to VDDA, VREF- is internally connected to VSSA.
4. Guaranteed by design, not tested in production.
5. For external trigger, a delay of 1/f_{ADC} must be added.

Input impedance

Equation 2

$$R_{AIN} < \frac{T_S}{f_{ADC} \times C_{ADC} \times \ln(2^{n+2})} - R_{ADC}$$

The formula above is used to determine the maximum external impedance allowed for an error below 1/4 of LSB. Here N = 12 (12-bit resolution), is derived from tests under f_{ADC} = 15MHz.

Electrical characteristics

Table 5-29 Maximum R_{AIN} at $f_{ADC} = 15\text{MHz}$ ⁽¹⁾

T_s (cycles)	t_s (μs)	Maximum R_{AIN} ($\text{k}\Omega$)
2.5	0.156	0.1
8.5	0.531	4.0
14.5	0.906	7.8
29.5	1.844	17.5
42.5	2.656	25.9
56.5	3.531	34.9
72.5	4.531	45.2
240.5	15.031	153.4

1. Guaranteed by design. Not tested in production.

Table 5-30 ADC static parameters ⁽¹⁾⁽²⁾

Symbol	Parameter	Conditions	Typical	Unit
ET	Comprehensive error	$f_{PCLK1} = 24\text{MHz}$, $f_{ADC} = 12\text{MHz}$, $R_{AIN} < 0.1 \text{ k}\Omega$, $V_{DDA} = 3.3\text{V}$, $T_A = 25^\circ\text{C}$	-6/+3	LSB
EO	Offset error		-2/+3	
EG	Gain error		+3	
ED	Differential linearity error		-1/+2	
EL	Integral linearity error		-3/+3	

- ADC Accuracy vs. Negative Injection Current: Injecting negative current on any standard (non-robust) analog input pins should be avoided as this significantly reduces the accuracy of the conversion being performed on another analog input. It is recommended to add a Schottky diode (pin to ground) to standard analog pins which may potentially inject negative current. Any positive injection current within the limits specified for $I_{INJ(PIN)}$ and $\Sigma I_{INJ(PIN)}$ in section 5.2 Absolute maximum rating does not affect the ADC accuracy.
- Guaranteed based on characterization. Not tested in production.

The implications of the ADC static parameters are seen below, and the corresponding schematic diagram is shown in Figure 5-14.

- ET = Total unadjusted error: The maximum deviation between the actual and ideal transmission curves.
- EO = Offset error: The deviation between the first actual conversion and the first ideal conversion.
- EG = Gain error: The deviation between the last ideal transition and the last actual transition.
- ED = Differential linearity error: The maximum deviation between the actual step and the ideal value.
- EL = Integral linearity error: The maximum deviation between any actual conversion and the associated line of the endpoint.

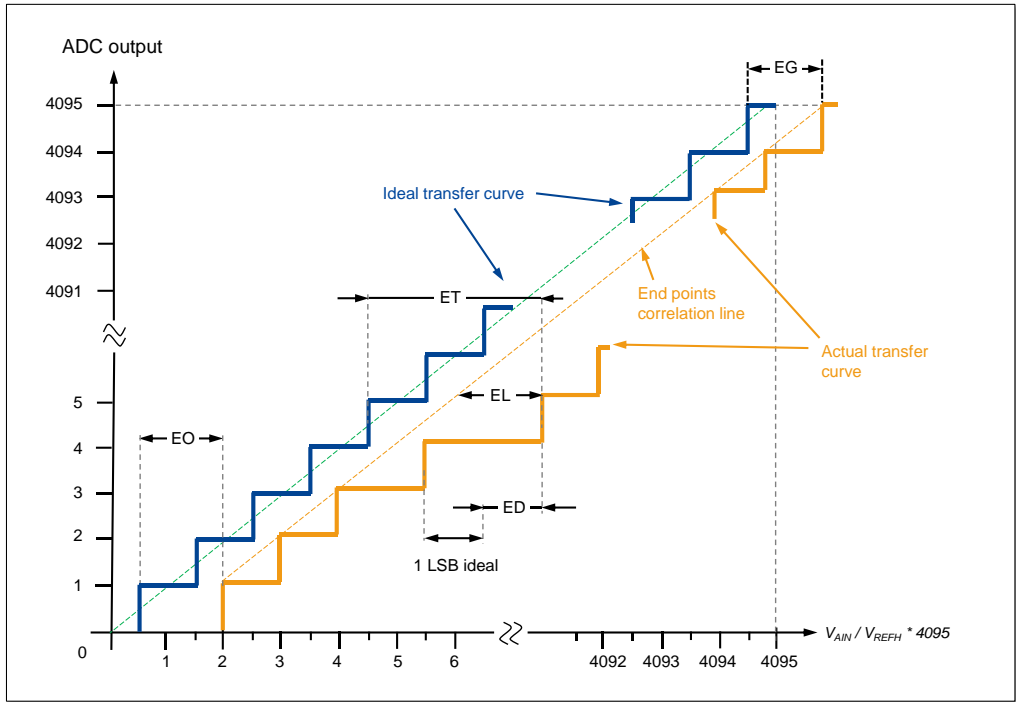

Figure 5-14 Schematic diagram of ADC static parameters

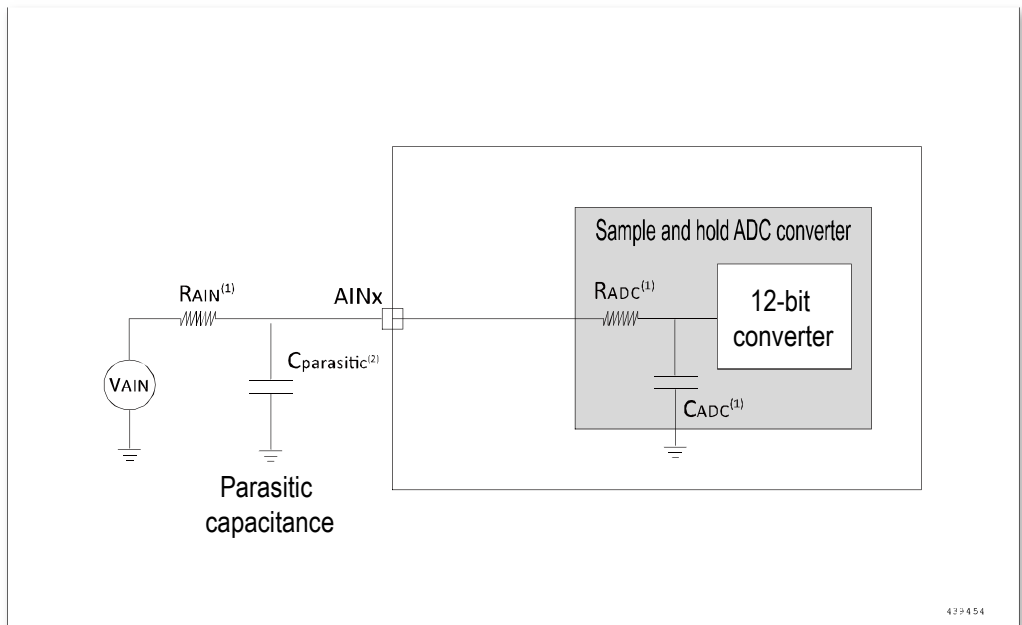

Figure 5-15 Typical connection diagram using the ADC

1. See Table 5-28 for the values of R_{AIN} , R_{ADC} and C_{ADC} .
2. $C_{parasitic}$ represents the capacitance of the PCB (dependent on soldering and PCB layout quality) plus the pad capacitance (roughly 7pF). A high $C_{parasitic}$ value will downgrade conversion accuracy. To remedy this, f_{ADC} should be reduced.

PCB design recommendations

The power supply must be connected as shown below. The 10nF capacitor in the figure must be a ceramic capacitor (good quality), and they should be as close as possible to the MCU chip.

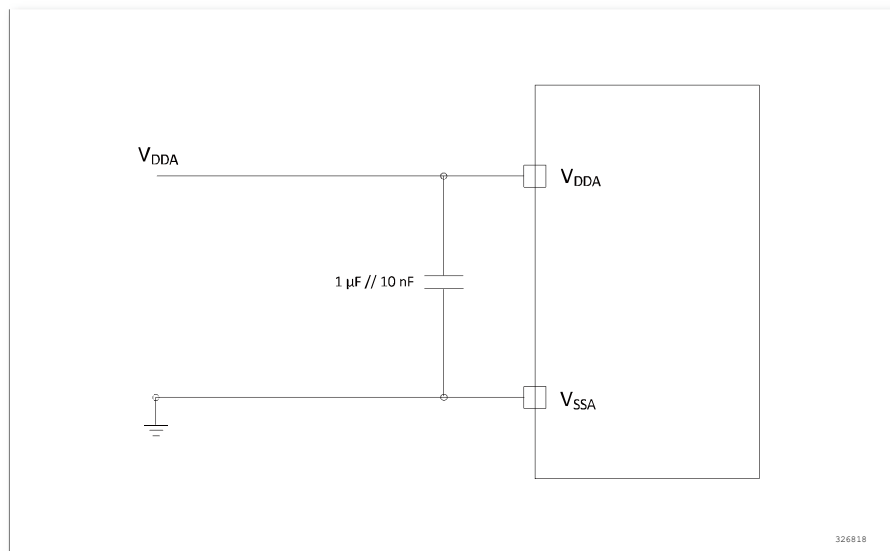

Figure 5-16 Power supply and reference power supply decoupling circuit

5.3.18 Temperature sensor characteristics

The temperature sensor is calculated using the formula below:

Temperature formula

$$TS_{adc} = 25 + \frac{Value * V_{DDA} - offset * 3300}{4096 * Avg_Slope}$$

Where offset is recorded in the lower 12bits of 0x1FFFF7F6

Table 5-31 Temperature sensor characteristics ⁽³⁾⁽⁴⁾

Symbol	Parameter	Minimum	Typical	Maximum	Unit
T _L ⁽¹⁾	V _{SENSE} linearity with respect to temperature	-10	-	+10	°C
Avg_Slope ⁽²⁾	Average slope	4.4	4.955	5.313	mV/°C
V ₂₅ ⁽¹⁾	Voltage at 25°C	1.086	1.465	1.744	V
t _{START} ⁽²⁾	Setup time	-	-	10	μS
t _{S_temp} ⁽²⁾	ADC sampling time when reading temperature	-	11.8	-	μS

1. Guaranteed based on characterization. Not tested in production.
2. Guaranteed by design. Not tested in production.
3. The shortest sampling time can be determined by application through multiple iterations.
4. VDD = 3.3V

5.3.19 Comparator characteristics

Table 5-32 Comparator characteristics ⁽¹⁾

Symbol	Parameter	Condition	Minimum	Typical	Maximum	Unit
t _{HYST}	Hysteresis	HYST = 00, MODE = 00	-	0	-	mV
		HYST = 01, MODE = 00	15	22	43	mV
		HYST = 10, MODE = 00	32	45	92	mV
		HYST = 11, MODE = 00	55	85	182	mV
		HYST = 00, MODE != 00	-	0	-	mV
		HYST = 01, MODE != 00	13	15	23	mV
		HYST = 10, MODE != 00	25.2	32	46.7	mV
		HYST = 11, MODE != 00	25.5	60	83.9	mV
V _{OFFSET}	Offset voltage	HYST = 00	-	±6	±10.4	mV
		HYST = 01	-	±5.5	±10	mV
		HYST = 10	-	±5	±9	mV
		HYST = 11	-	±4	±7	mV
t _{DELAY}	Propagation delay	MODE = 00	3.7	10.7	43	ns
		MODE = 01	10.5	34.9	83	ns
		MODE = 10	13.8	49	114	ns
		MODE = 11	22.2	86	194.5	ns
I _q	Average working current	MODE = 00	6.5	45	89.2	uA
		MODE = 01	3.3	8.6	24.7	uA
		MODE = 10	2.6	6	25.4	uA
		MODE = 11	1.7	4.6	16	uA

1. Guaranteed by design, not tested in production.

6 Package dimensions

6.1 LQFP48

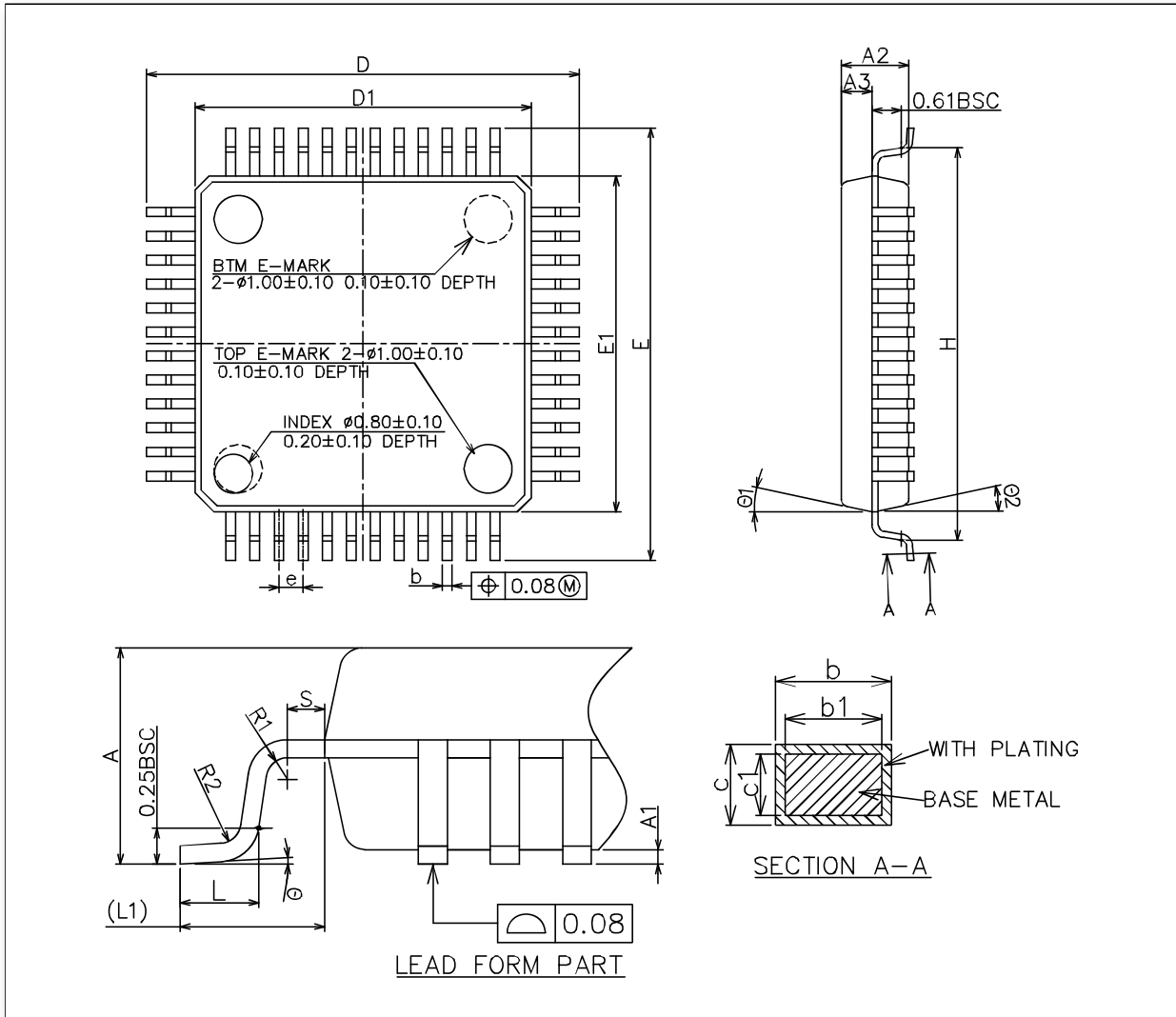

Figure 6-1 LQFP48 package dimension

1. The figure is not drawn to scale.
2. Dimensions are in millimeters.

Package dimensions

Table 6-1 LQFP48 package dimension details

ID	Millimeters		
	Minimum	Typical	Maximum
A	-	-	1.6
A1	0.05	-	0.15
A2	1.35	1.4	1.45
A3	0.59	0.64	0.69
b	0.18	-	0.27
b1	0.17	0.20	0.23
c	0.13	-	0.18
c1	0.12	0.127	0.134
D	8.80	9.00	9.20
D1	6.90	7.00	7.10
E	8.80	9.00	9.20
E1	6.90	7.00	7.10
e	-	0.50	-
L	0.45	0.60	0.75
L1	1.00REF		
L2	0.25BSC		
R1	0.08	-	-
R2	0.08	-	0.2
S	0.2	-	-
θ	0°	3.5°	7°
$\theta 1$	0°	-	-
$\theta 2$	11°	12°	13°
$\theta 3$	11°	12°	13°

6.2 LQFP32

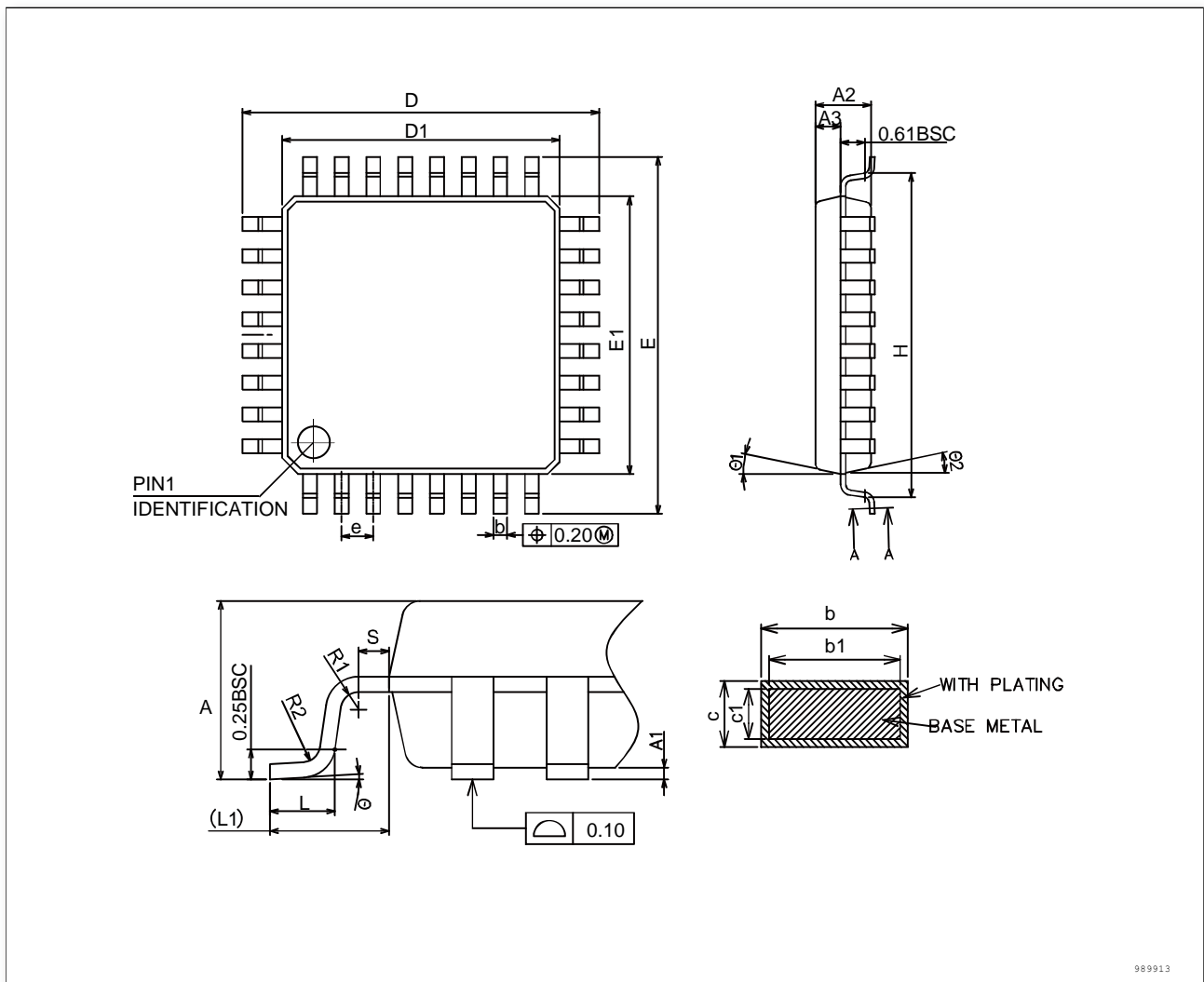

Figure 6-2 LQFP32 package dimension

1. The figure is not drawn to scale.
2. Dimensions are in millimeters.

Package dimensions

Table 6-2 LQFP32 package dimension details

ID	Millimeters		
	Minimum	Typical	Maximum
A	-	-	1.60
A1	0.05	-	0.15
A2	1.35	1.40	1.45
A3	0.59	0.64	0.69
b	0.33	-	0.42
b1	0.32	0.35	0.38
c	0.13	-	0.18
c1	0.117	0.127	0.137
D	8.80	9.00	9.20
D1	6.90	7.00	7.10
E	8.80	9.00	9.20
E1	6.90	7.00	7.10
e	-	0.80	-
H	8.14	8.17	8.20
L	0.50	-	0.70
L1	1.00REF		
R1	0.08	-	-
R2	0.08	-	0.20
S	0.20	-	-
θ	0°	3.5°	7°
θ_1	11°	12°	13°
θ_2	11°	12°	13°

6.3 QFN32

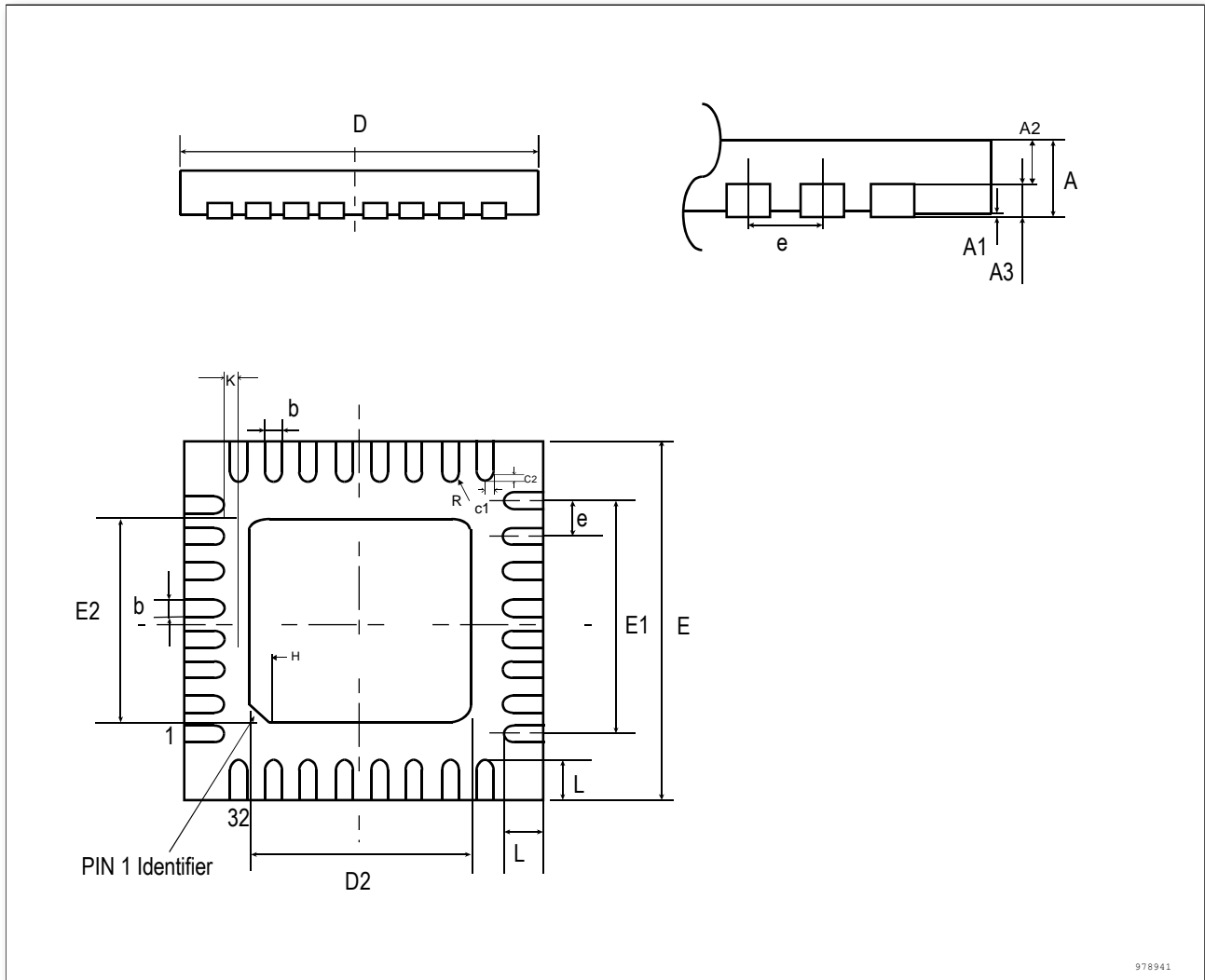

Figure 6-3 QFN32 package dimension

1. The figure is not drawn to scale.
2. Dimensions are in millimeters.

Package dimensions

Table 6-3 QFN32 package dimension details

ID	Millimeters		
	Minimum	Typical	Maximum
A	0.7	0.75	0.80
A1	0.00	0.02	0.05
A2	0.50	0.55	0.60
A3	0.20REF		
b	0.20	0.25	0.30
D	4.90	5.00	5.10
E	4.90	5.00	5.10
D2	3.40	3.50	3.60
E2	3.40	3.50	3.60
e	-	0.5	-
H	0.30REF		
K	0.35REF		
L	0.35	0.40	0.45
R	0.09	-	-
c1	-	0.08	-
c2	-	0.08	-
N	Pin count = 32		

6.4 QFN28

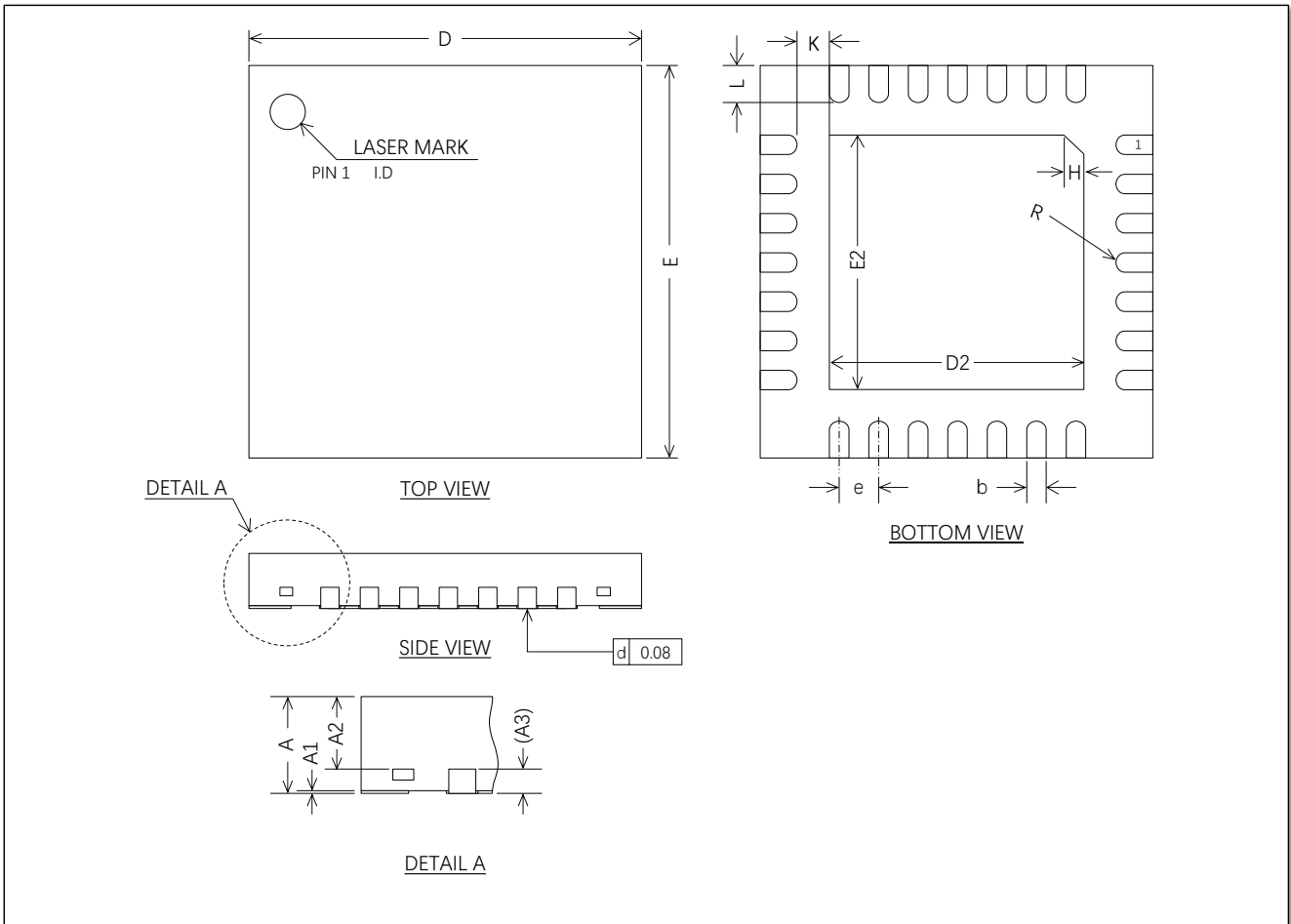

Figure 6-4 QFN28 package dimension

1. The figure is not drawn to scale.
2. Dimensions are in millimeters.

Package dimensions

Table 6-4 QFN28 package dimension details

ID	Millimeters		
	Minimum	Typical	Maximum
A	0.70	0.75	0.80
A1	0.00	0.02	0.05
A2	0.50	0.55	0.60
A3	0.20REF		
b	0.15	0.20	0.25
D	3.90	4.00	4.10
E	3.90	4.00	4.10
D2	2.50	2.60	2.70
E2	2.50	2.60	2.70
e	-	0.40	-
H	0.35REF		
K	0.30REF		
L	0.35	0.40	0.45
R	0.075	-	-

6.5 TSSOP20

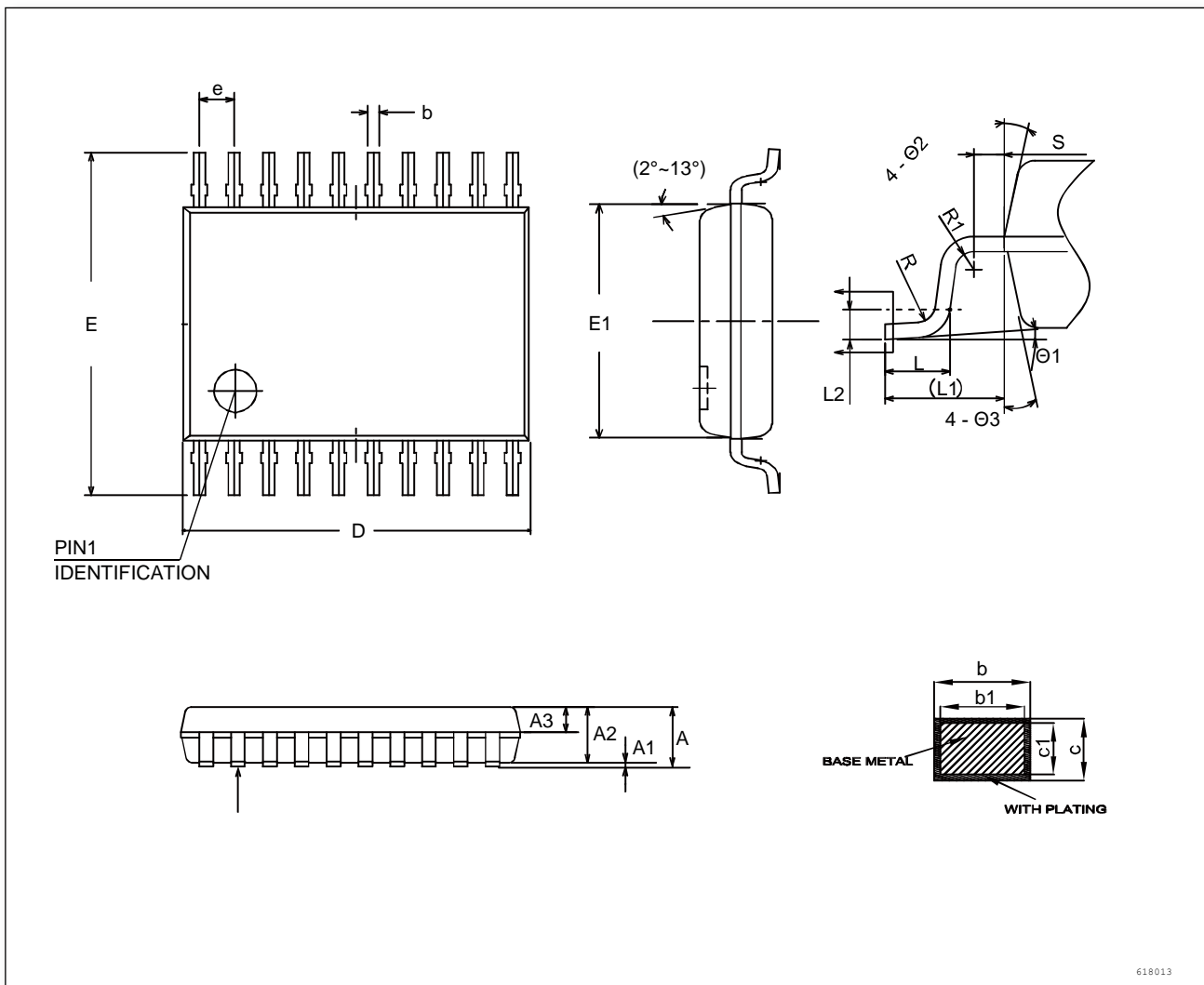

Figure 6-5 TSSOP20 package dimension

1. The figure is not drawn to scale.
2. Dimensions are in millimeters.

Package dimensions

Table 6-5 TSSOP20 package dimension details

ID	Millimeters		
	Minimum	Typical	Maximum
A	-	-	1.20
A1	0.05	-	0.15
A2	-	-	1.05
A3	0.34	-	0.54
b	0.20	-	0.28
c	0.10	-	0.19
c1	0.10	-	0.15
D	6.40	6.45	6.60
E	6.20	6.40	6.60
E1	-	4.35	4.50
e	0.65BSC		
L	0.45	0.60	0.75
L2	0.25BSC		
L1	1.0REF		
R	0.09	-	-
θ1	0°	-	8°

7 Revision history

Table 7-1 Revision history

Date	Revision	Description
2023/06/21	Rev1.07	<ol style="list-style-type: none"> 1. Added frequency deviation data across -20°C to 85°C in HSI oscillator characteristics ⁽¹⁾⁽²⁾ 2. Added Peripheral status in different power modes table 3. Updated the format of ordering table 4. Fixed the Power scheme figure
2022/11/28	Rev1.06	<ol style="list-style-type: none"> 1. Added QFN28 package
2022/08/10	Rev1.05	<ol style="list-style-type: none"> 1. Added package power dissipation value 2. Added the limit value of each gear of PVD 3. Added the power consumption limit value of low power modes 4. Added the LSI frequency limit value 5. Added the limit value of temperature sensor V₂₅ and slope 6. Updated SPI maximum speed 7. Updated COMP characteristics table, added limit value 8. Updated GPIO pull-up and pull-down equivalent resistor values 9. Added the limit value of IO characteristics
2022/06/27	Rev1.04	Added F0141C
2022/04/26	Rev1.03	<ol style="list-style-type: none"> 1. Updated NRST & OSC application diagram 2. Added temperature range description in the marking information 3. Added ENOB to ADC parameters 4. Added AF8 to GPIO multiplexing table 5. Modified maximum value at room temperature in low power mode 6. Newly added the schematic diagram of ADC static parameters
2022/03/31	Rev1.02	Added power consumption in Sleep mode
2022/01/21	Rev1.01	Fixed the maximum value of voltage characteristics
2022/01/04	Rev1.0	<ol style="list-style-type: none"> 1. Fixed I2C communication diagram wrong description 2. Updated COMP pin name to be compatible with the description on User Manual
2021/12/06	Rev0.6	First public release